

# Tragwerksentwurf III

## *Structural Design III*

Joseph Schwartz · Philippe Block

BACHELOR

MASTER

Tragwerksentwurf

Tragwerksentwurf

Tragwerksentwurf

Tragwerksentwurf

Computational

Computational

Architektur

Kraft

I

II

III

IV

Structural

Structural

und

Material

Design I

Design II

Tragwerk

Form

Form & Force

Material

Entwurfsprojekt

Computational  
Graphic Statics

Form-finding  
and Fabrication

Entwurfsprojekt

Geschichte  
und Theorie

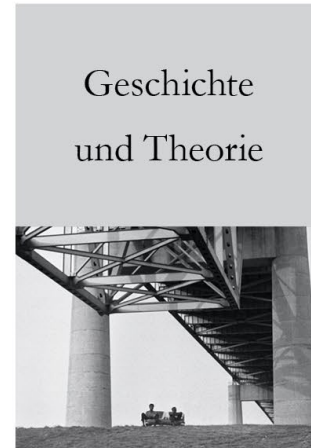
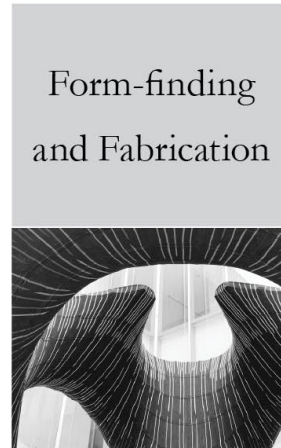
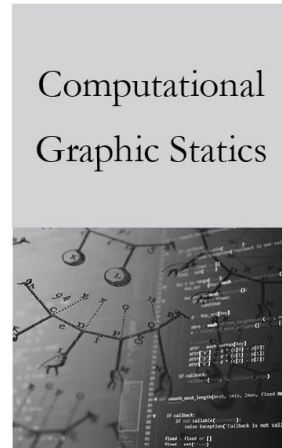
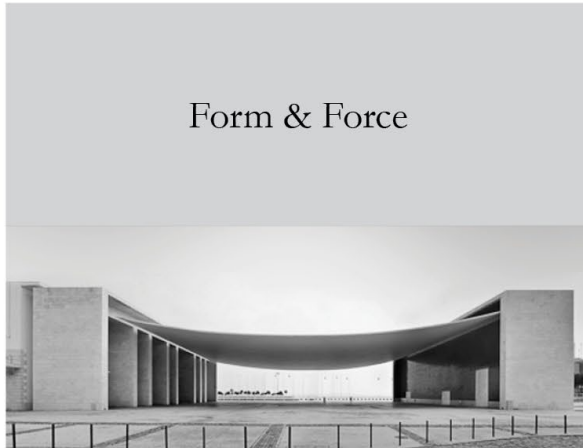

## BACHELOR

Tragwerksentwurf

I

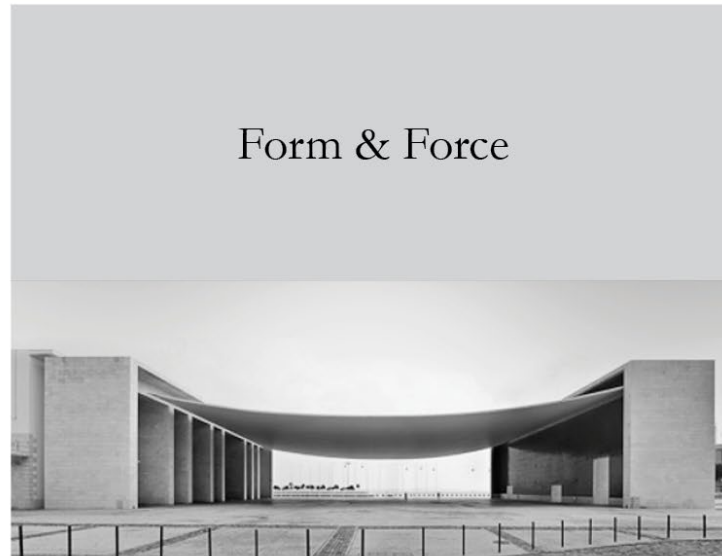

Tragwerksentwurf

II

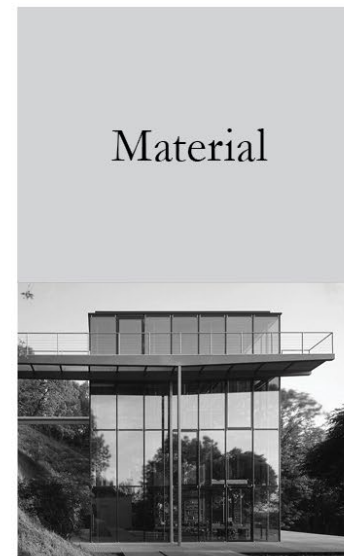

Tragwerksentwurf

III

Tragwerksentwurf

IV

**TEI-TEIII: Verstehen, wie Strukturen funktionieren****TEI-TEIV: Entwerfen von Tragwerken**



Tragwerksentwurf  
*Structural Design*



1. Gleichgewicht  
*1. Equilibrium*

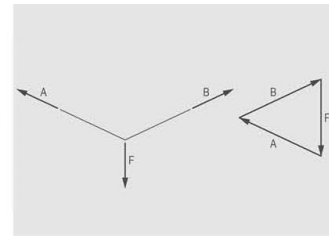

2. Graphische Statik  
*2. Graphic statics*



3. Seile  
*3. Cables*



4. Bogen  
*4. Arches*



5. Bogen-Seil  
*5. Arch-cables*

## Tragwerksentwurf I *Structural Design I*

## Tragwerksentwurf II *Structural Design II*

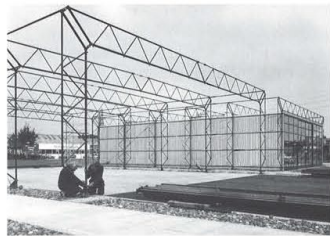

6. Fachwerke  
*6. Trusses*



7. Balken  
*7. Beams*



8. Rahmen  
*8. Frames*



9. Platten  
*9. Plates*



10. Stützen  
*10. Columns*



11. Nachhaltigkeit  
*11. Sustainability*



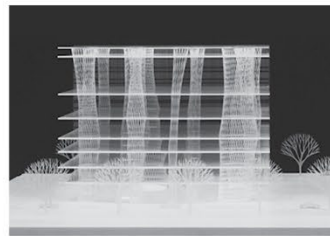

Architektur und Tragwerk  
*Architecture and Structure*



1. Stahl  
*1. Steel*



2. Stahlbeton  
*2. Reinforced concrete*

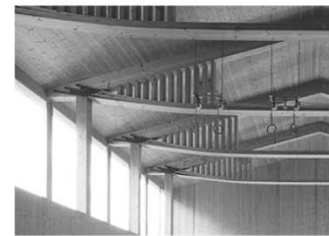

3. Holz  
*3. Timber*



4. Mauerwerk  
*4. Masonry*

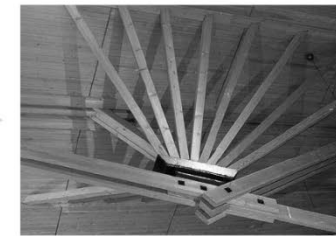

5. Konstruktionsdetails  
*5. Construction details*

### Tragwerksentwurf III *Structural Design III*

### Tragwerksentwurf IV *Structural Design IV*



Entwerfen von Tragwerken I  
*Design of structures I*



Entwerfen von Tragwerken II  
*Design of structures II*

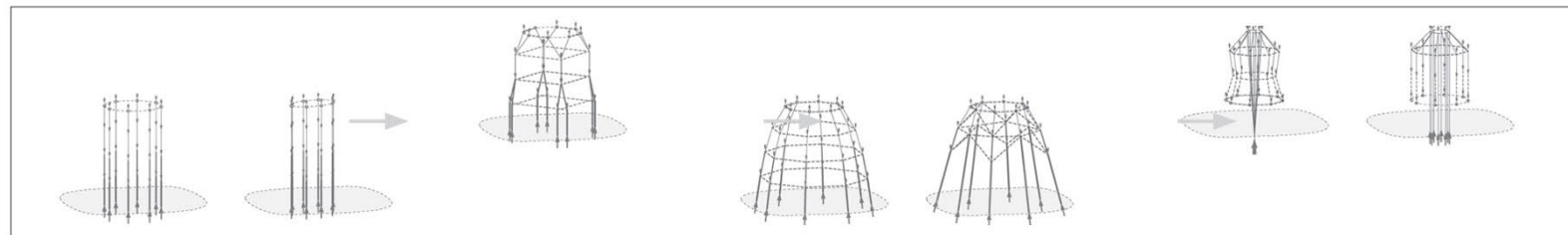

Entwurfsprojekt  
*Design project*

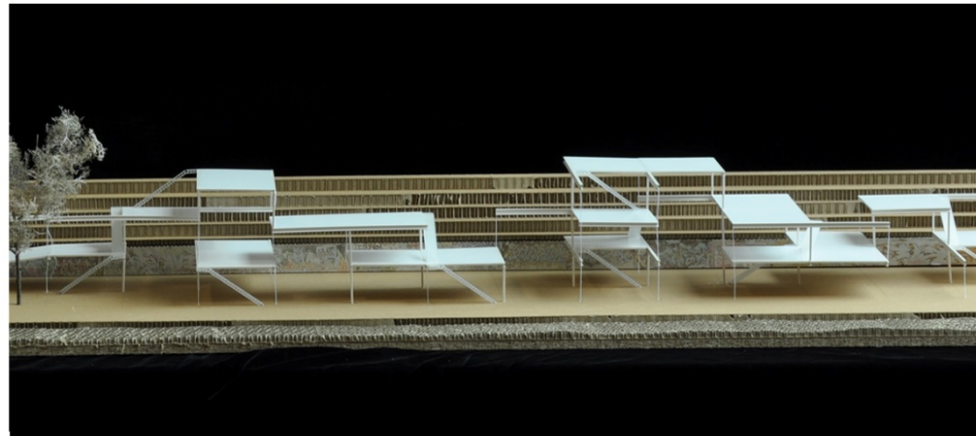
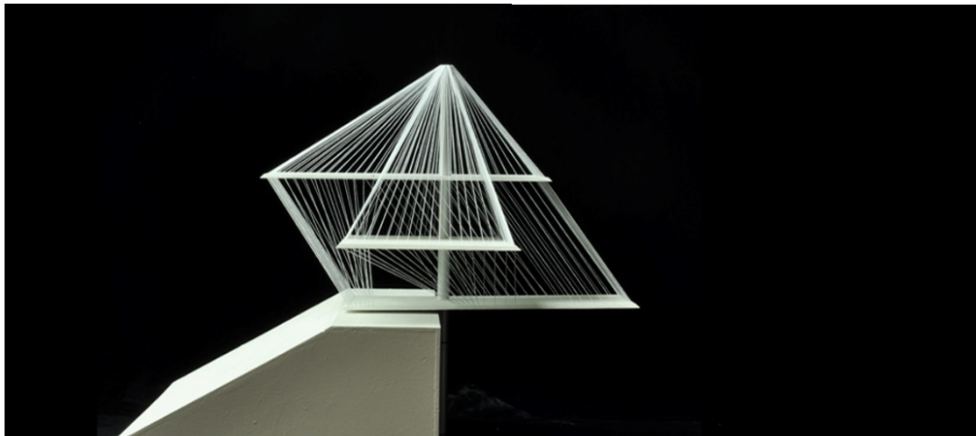
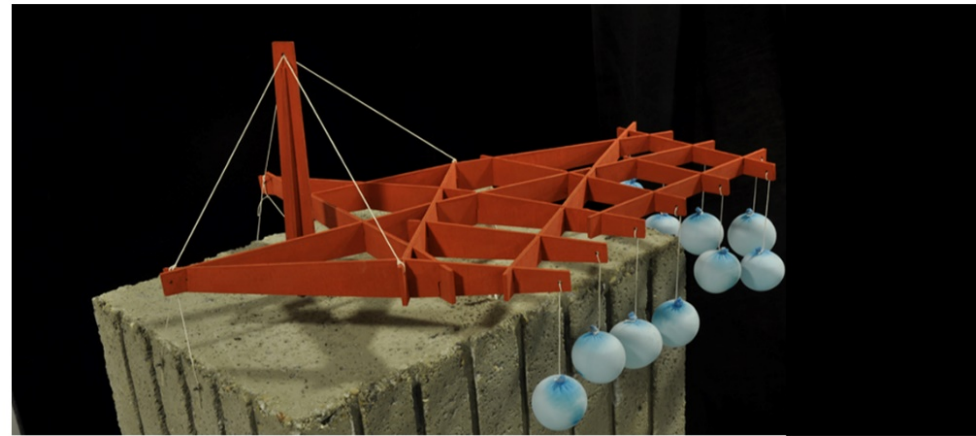
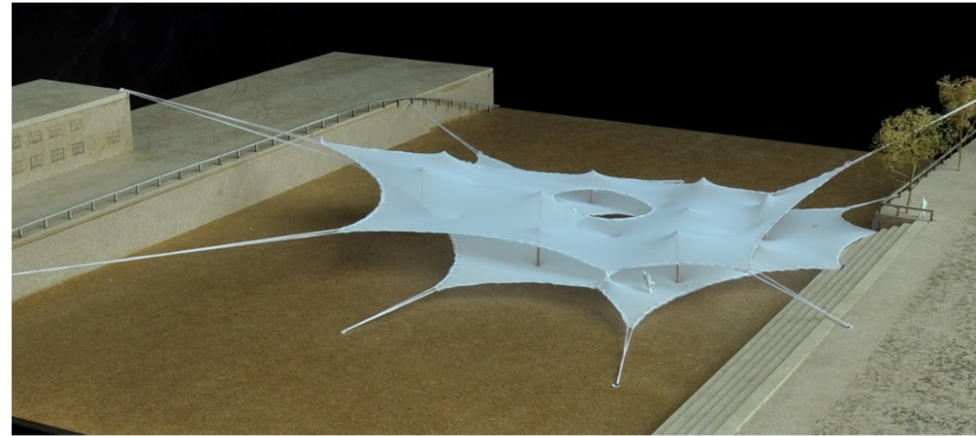

# Architektur und Tragwerk





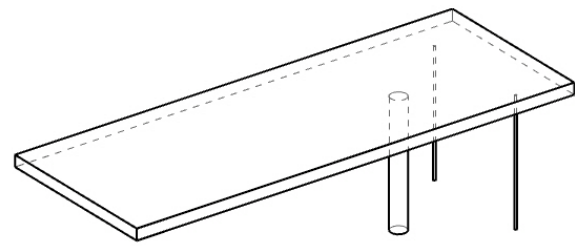
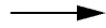
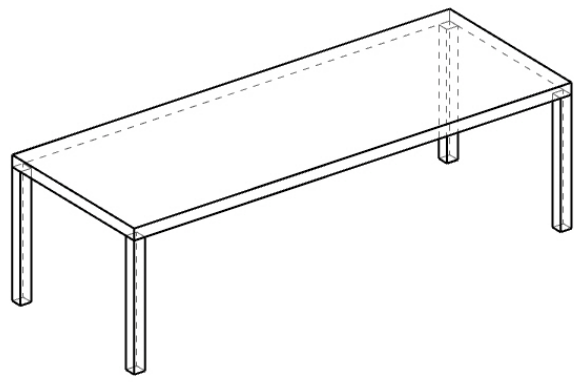

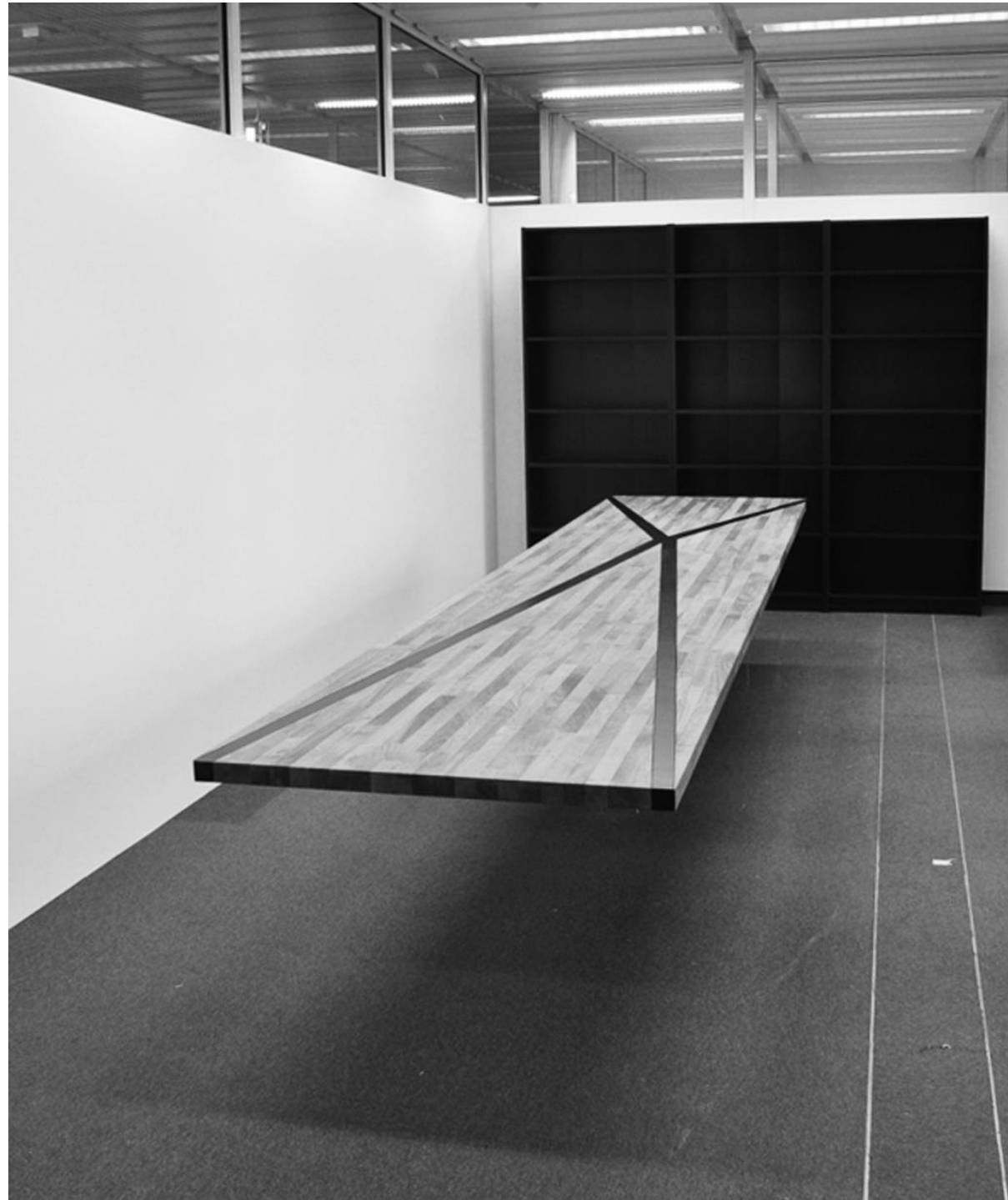

Counterpoise, Zürich, 2008, Professur für Tragwerksentwurf



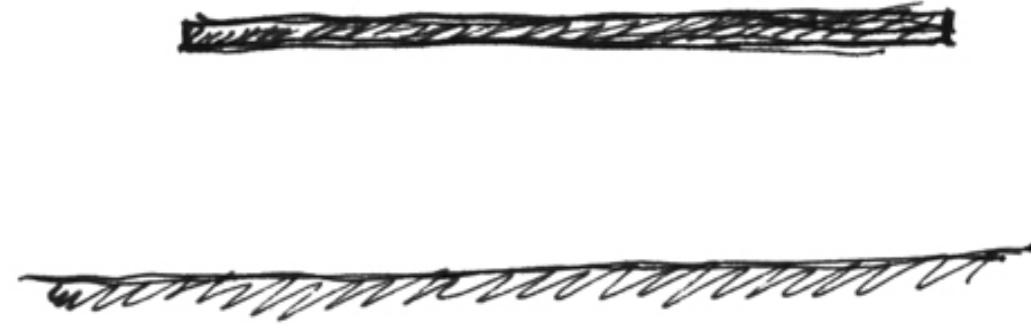

Der Begriff ‚Tisch‘ hat seine etymologischen Wurzeln im griechischen dishos, die Scheibe, und beschreibt ein Möbel welches charakterisiert ist durch die Horizontalität der Tischplatte. Das Projekt Counterpoise ist der Versuch einer Betonung dieser Horizontalität durch die Erzeugung eines Ausdrucks von Schweben mittels kombinatorischer Variation von typischem Tragverhalten.

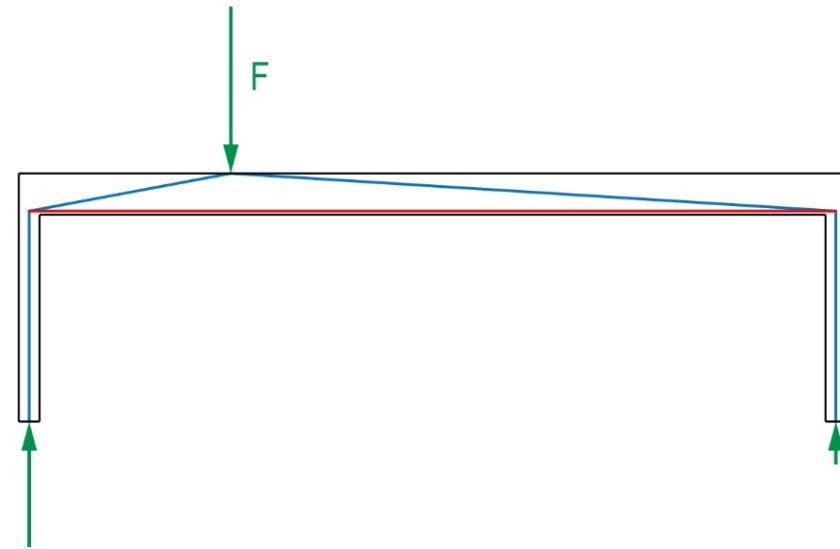
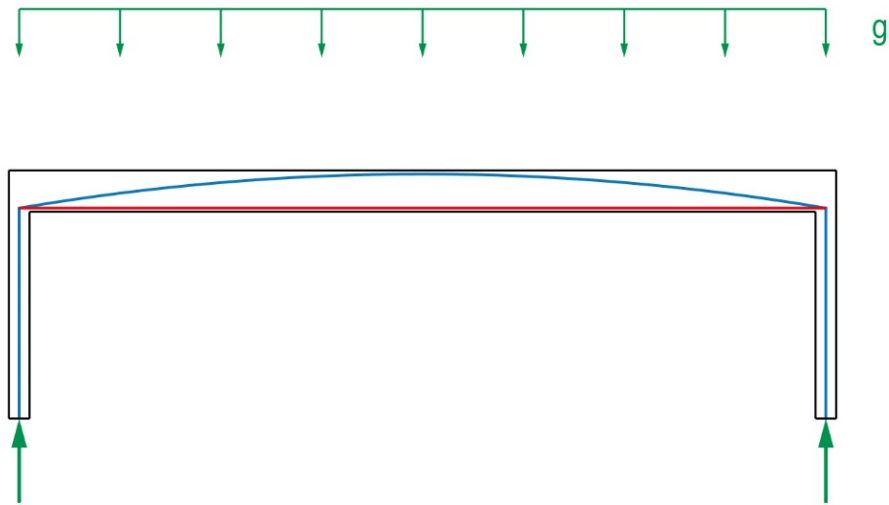

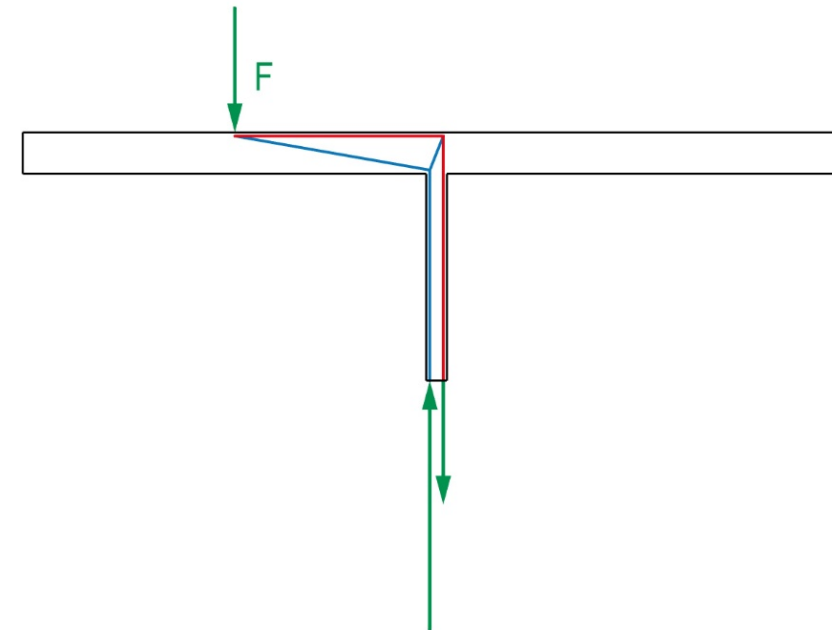
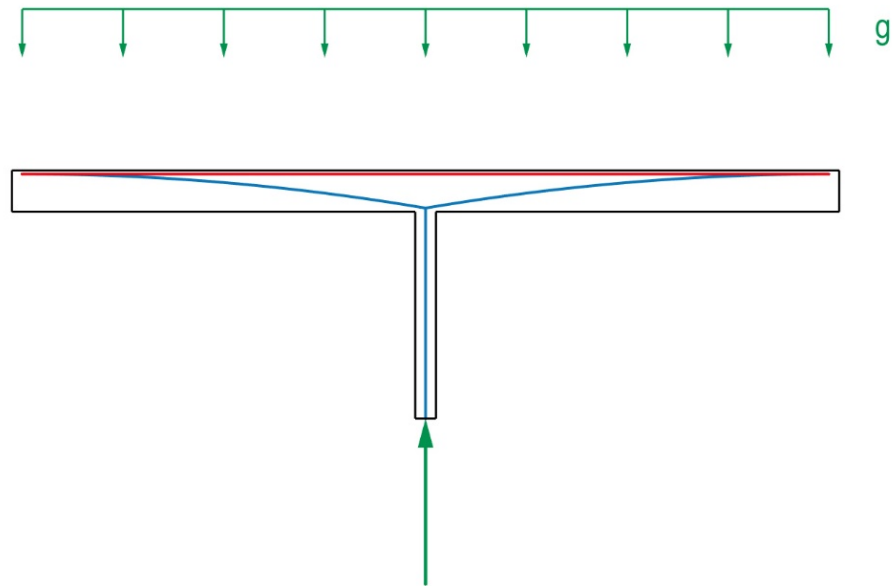

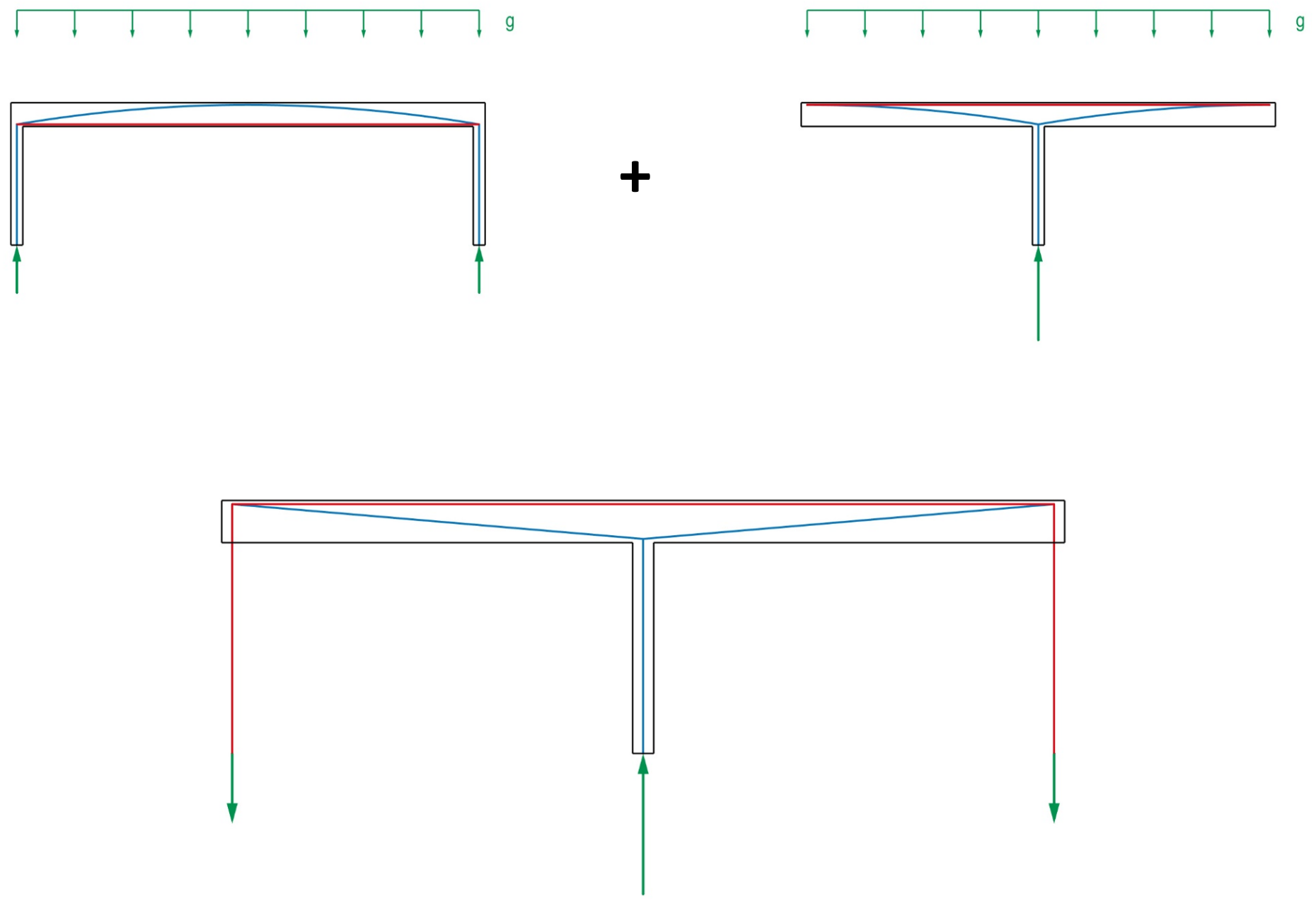

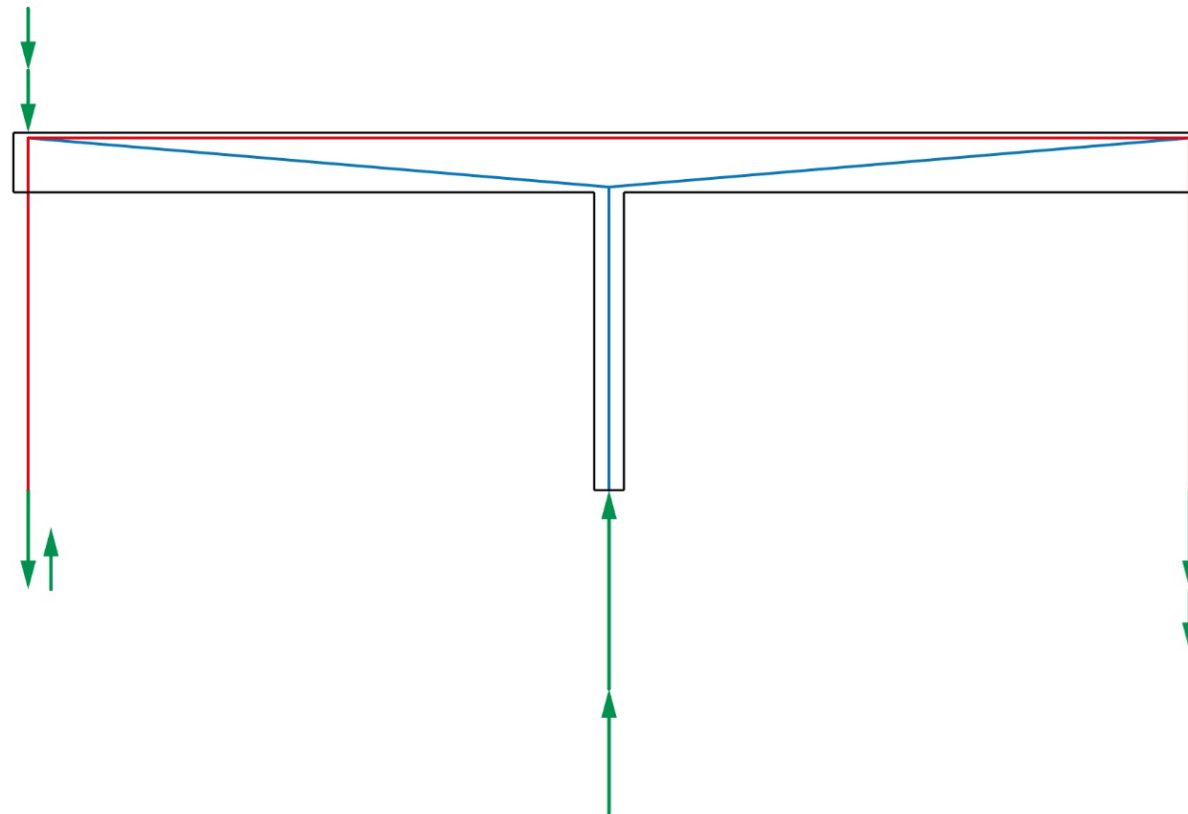



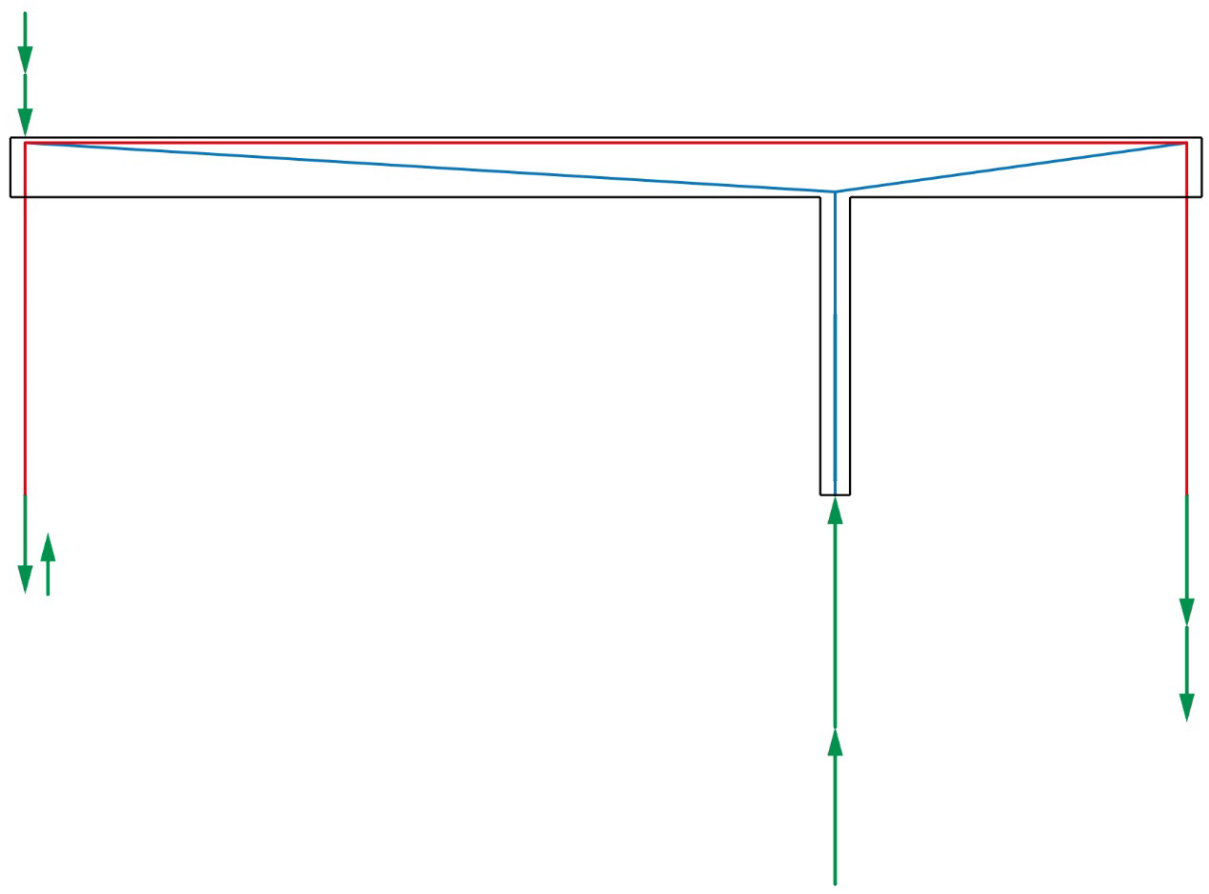

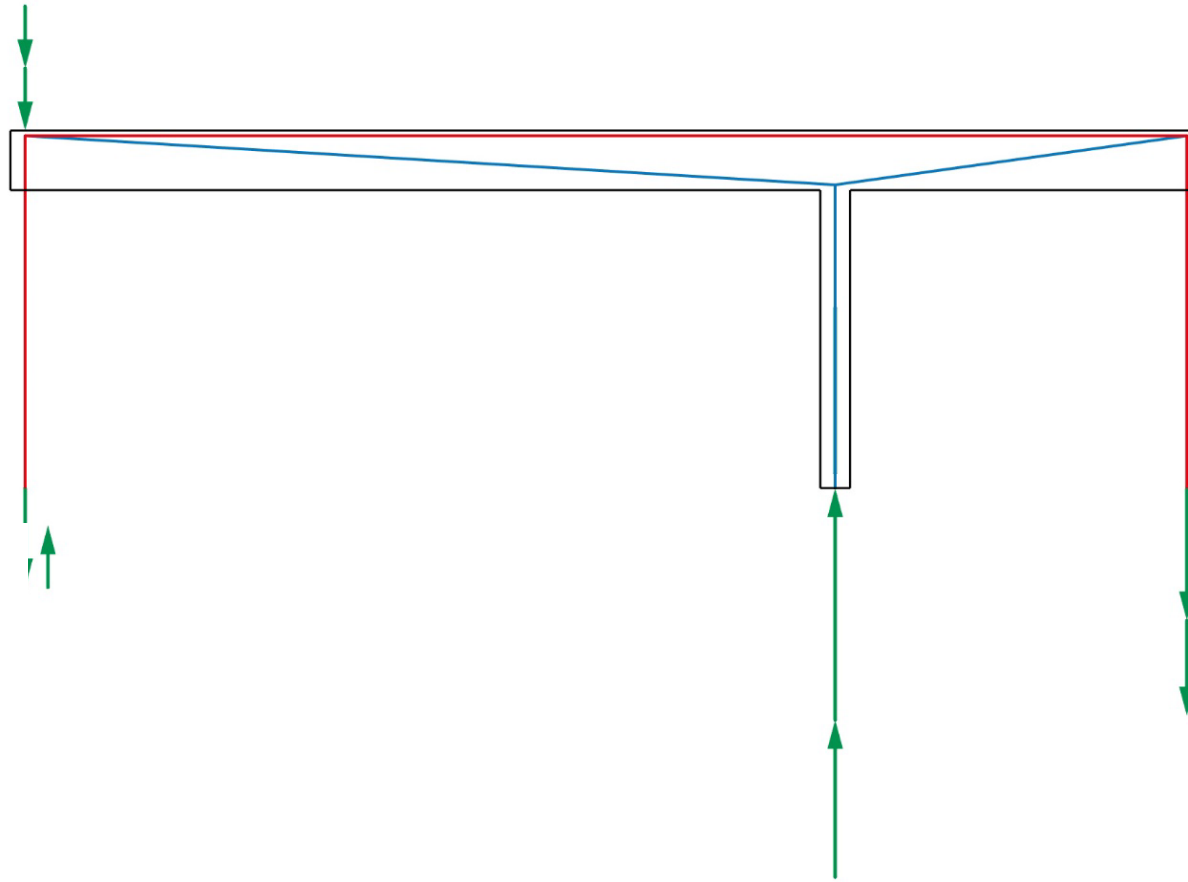

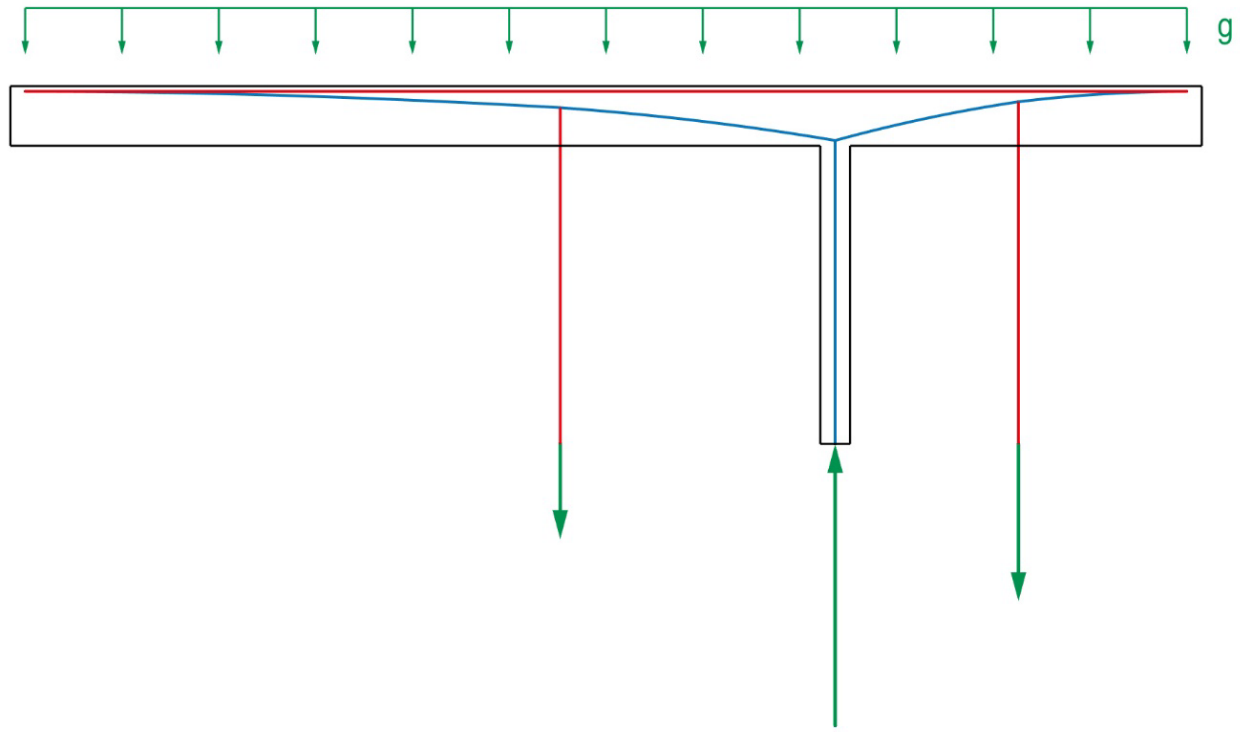
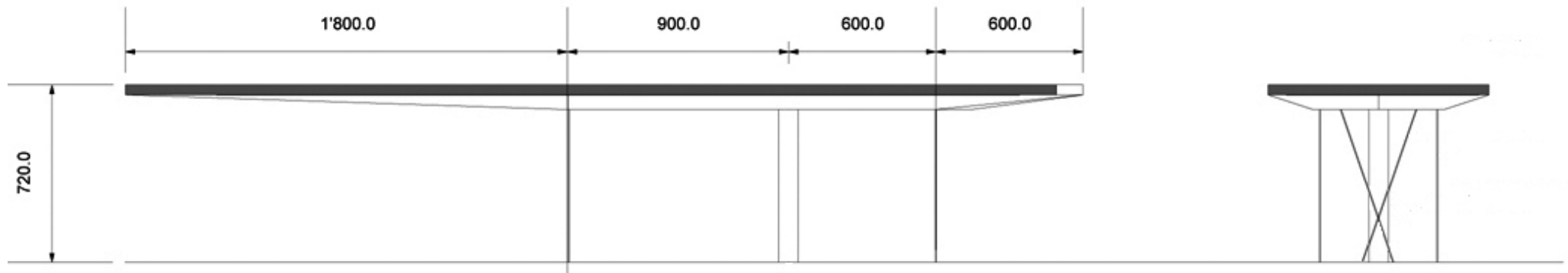



Counterpoise, Zürich, 2008, Professur für Tragwerksentwurf



Counterpoise, Zürich, 2008, Professur für Tragwerksentwurf



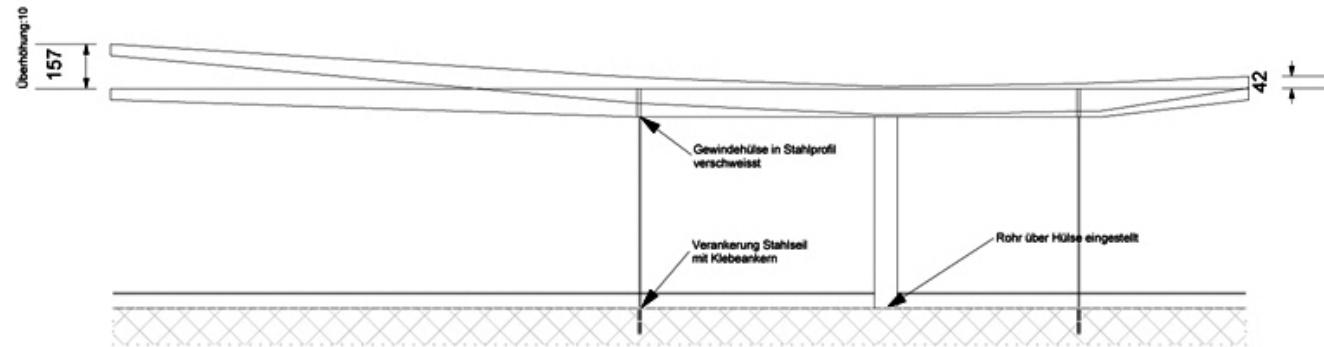

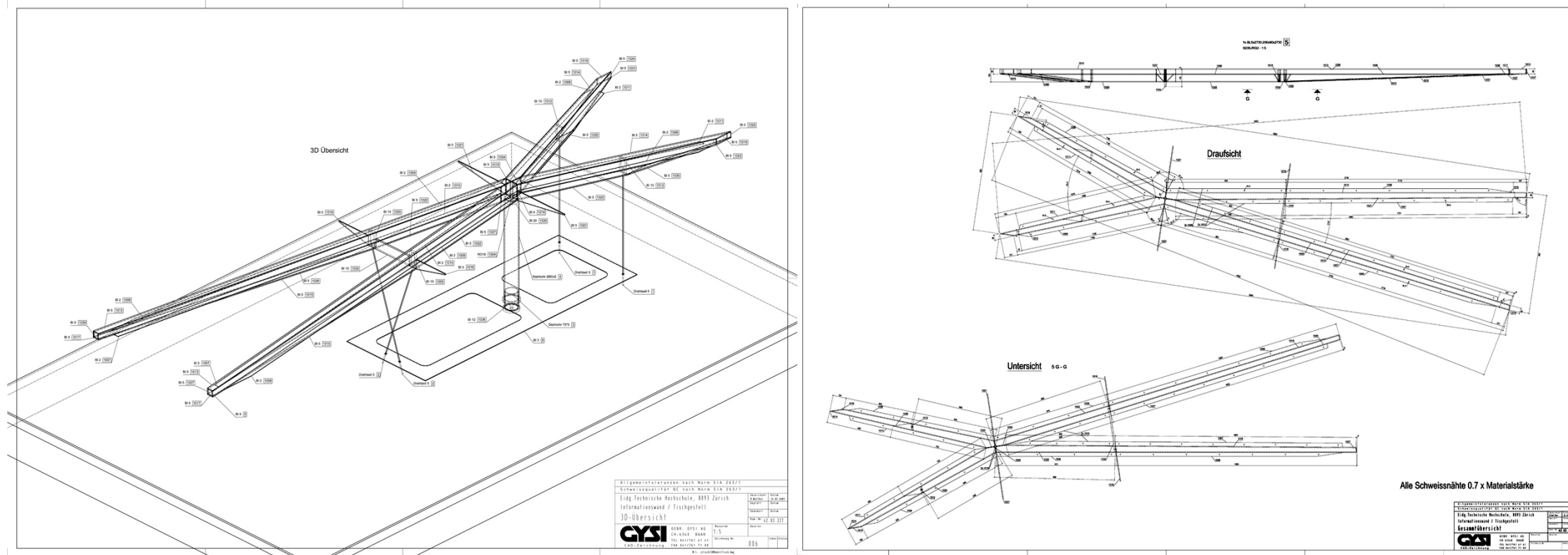

Counterpoise, Zürich, 2008, Professur für Tragwerksentwurf

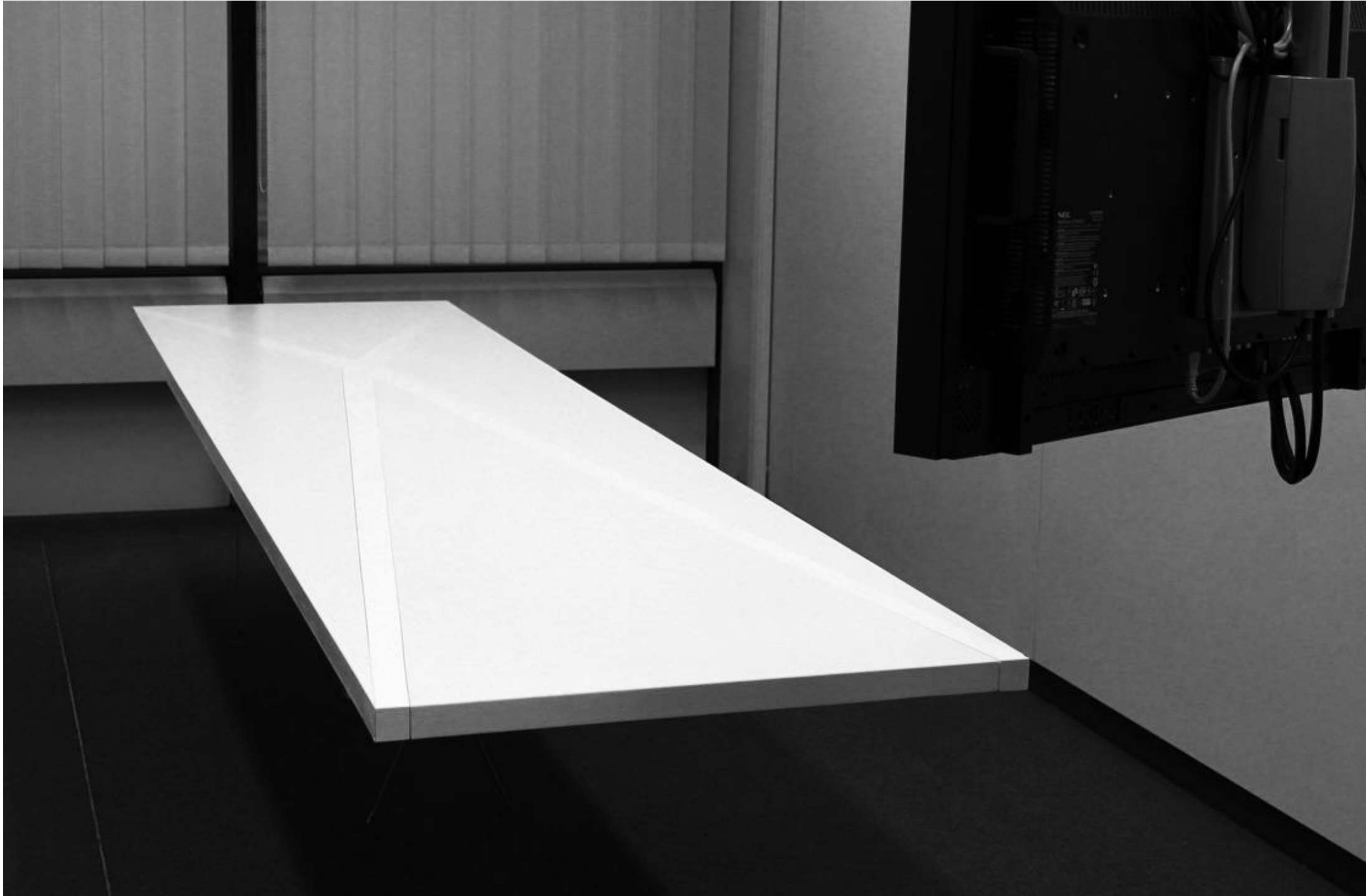

Counterpoise, Zürich, 2008, Professur für Tragwerksentwurf

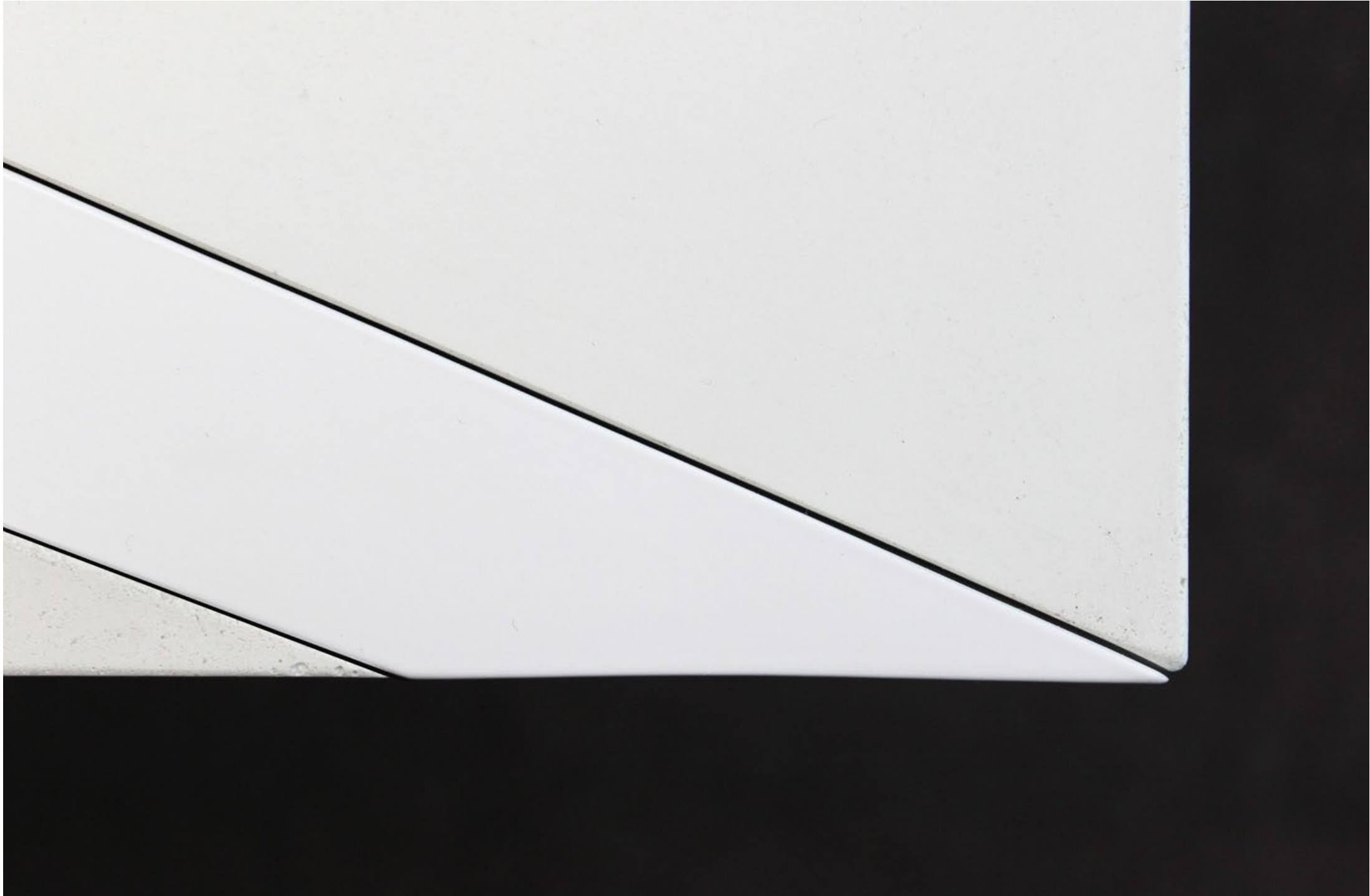

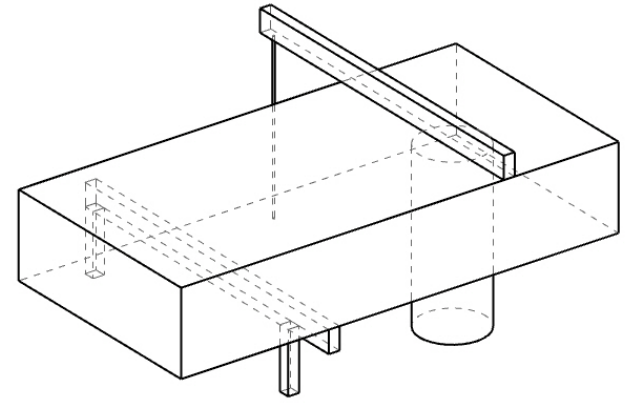
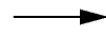
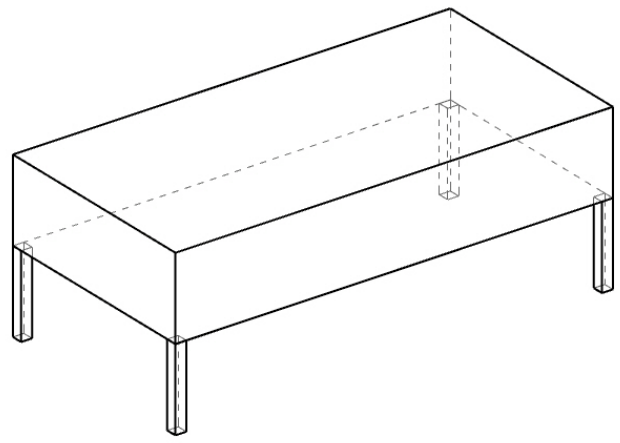





Maison à Floirac, Bordeaux, 1994-1998, Arch.: Rem Koolhaas, Ing: Cecil Balmond.



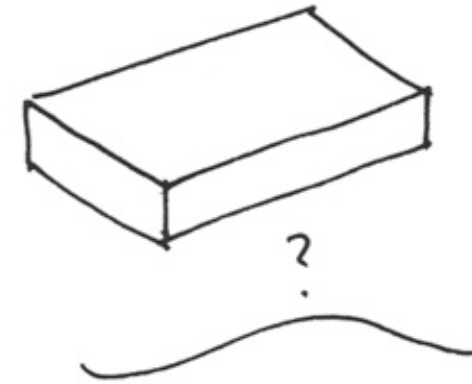
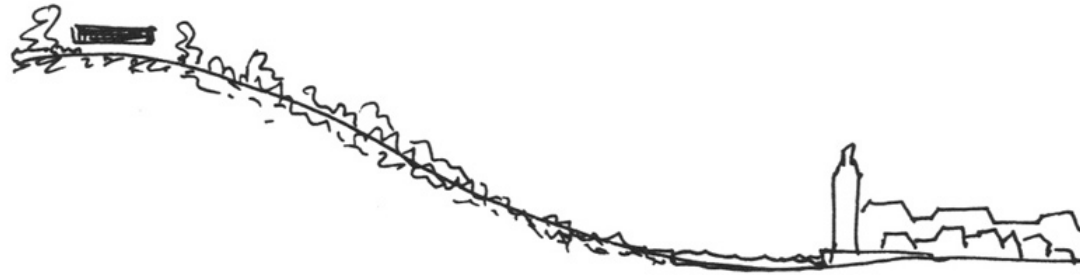

“Rem Koolhaas phones me. As usual the voice is urgent, full of convictions and ambitions, the language poised beautifully on extreme polarities. He has an unusual request, to make a villa in Bordeaux ‘fly’. The project is on a fantastic site with panoramic views over the rich, wine-laden city stretching along the river.”

Cecil Balmond

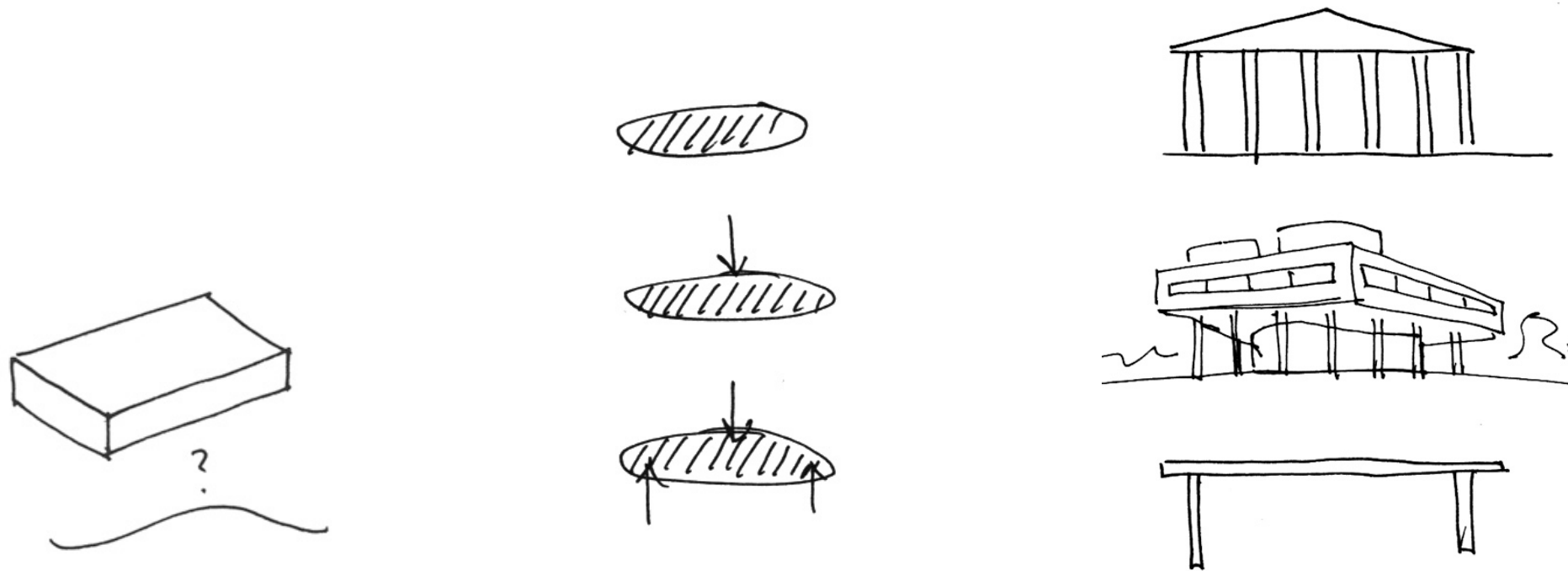

“No matter how the columns were placed beneath the load the generic concept of table came back, and with it the imprint of an ‘anchor’ killing off the ambition.”

Cecil Balmond

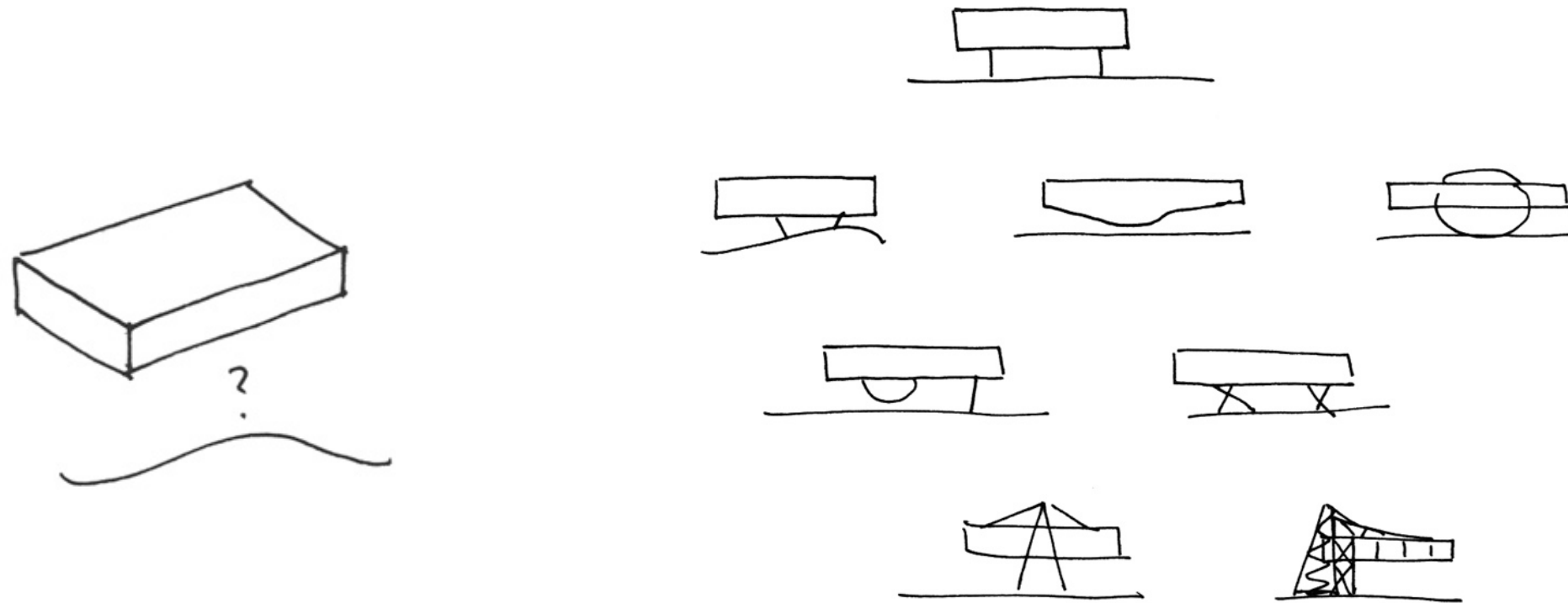

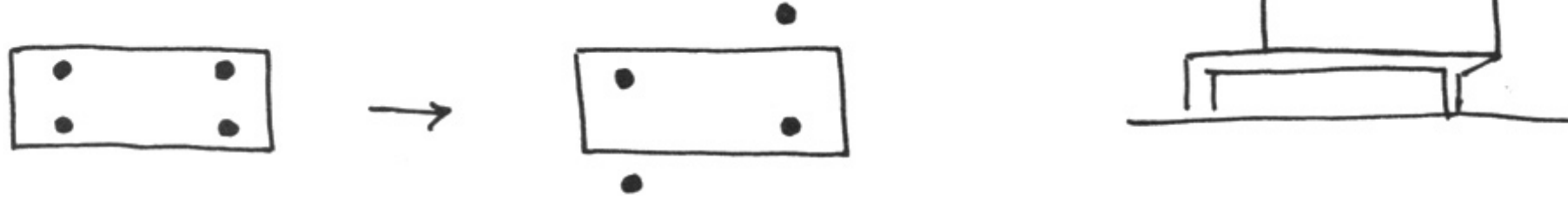

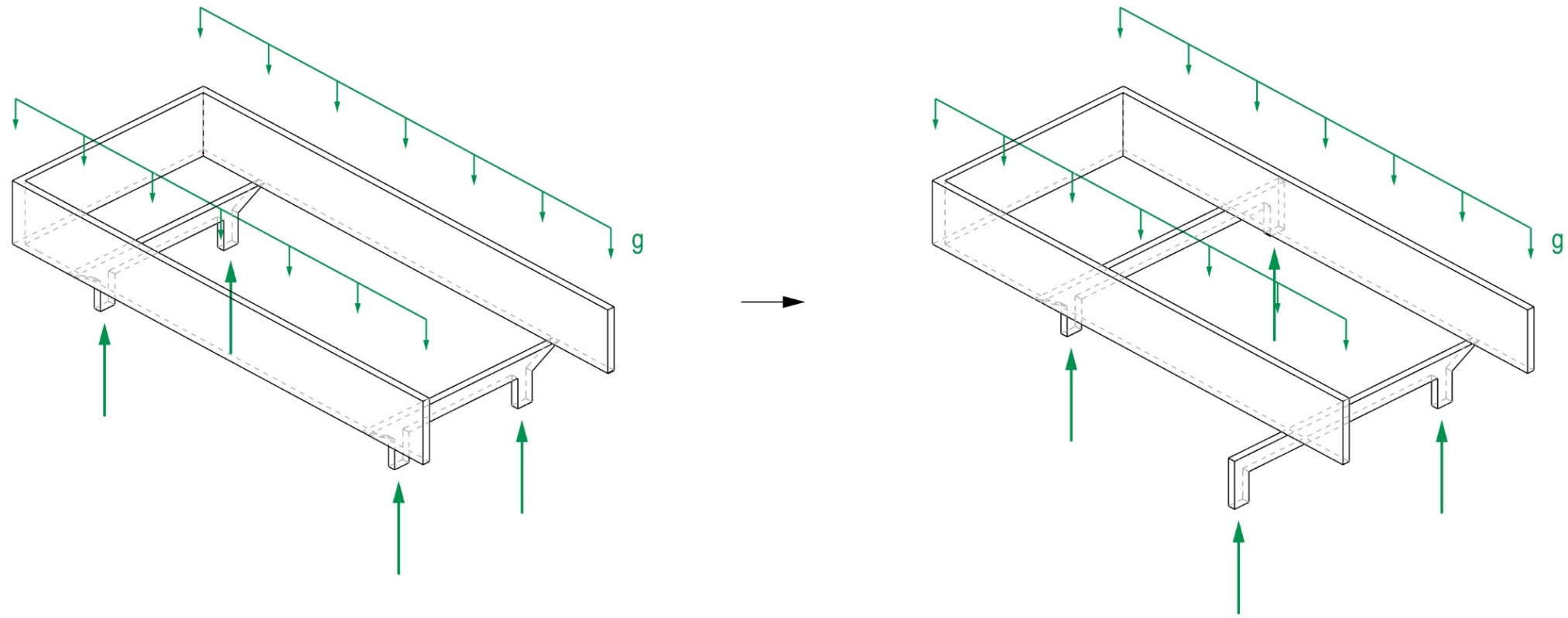

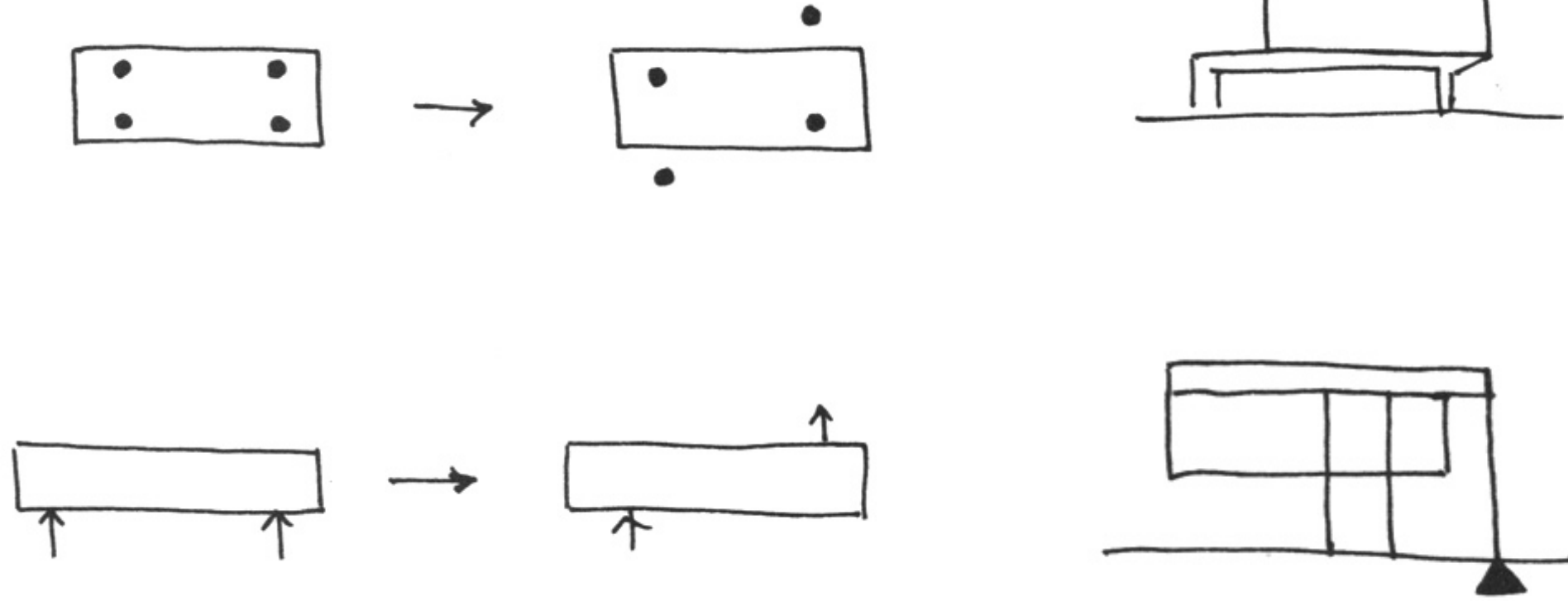



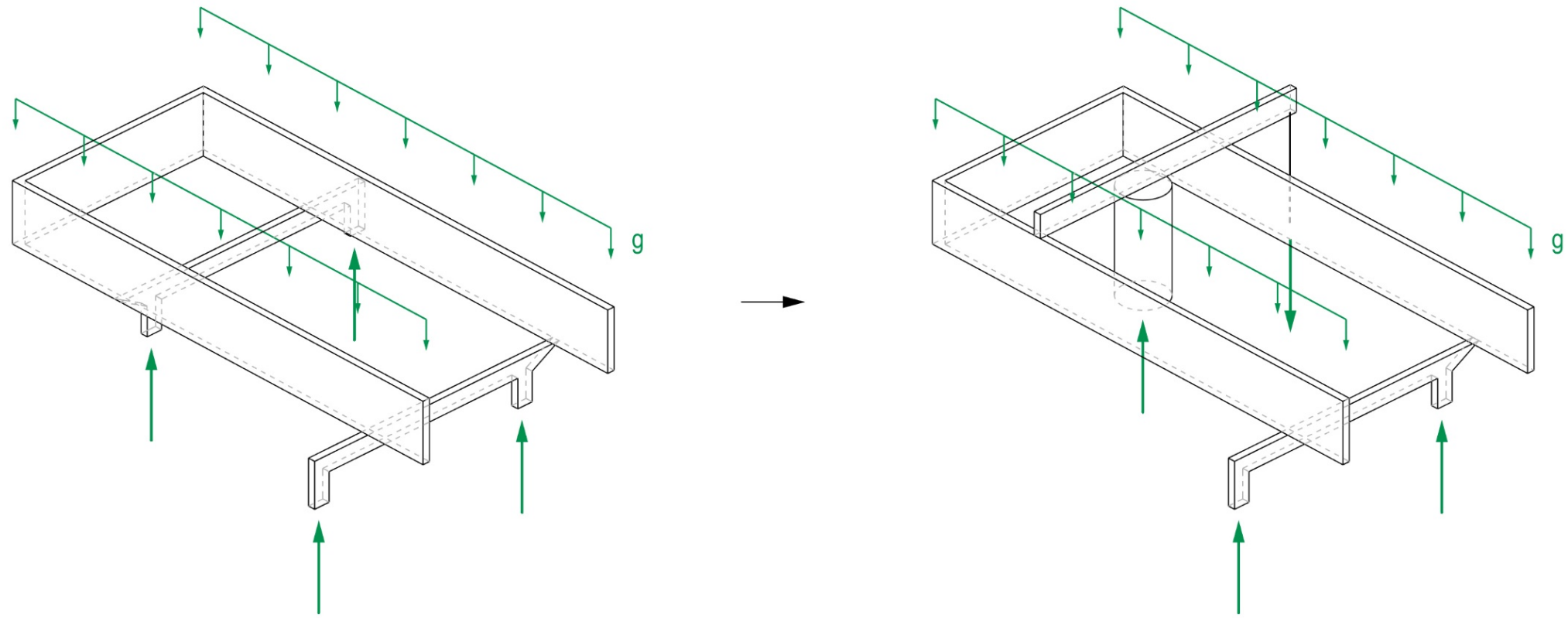

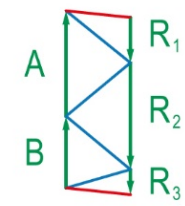
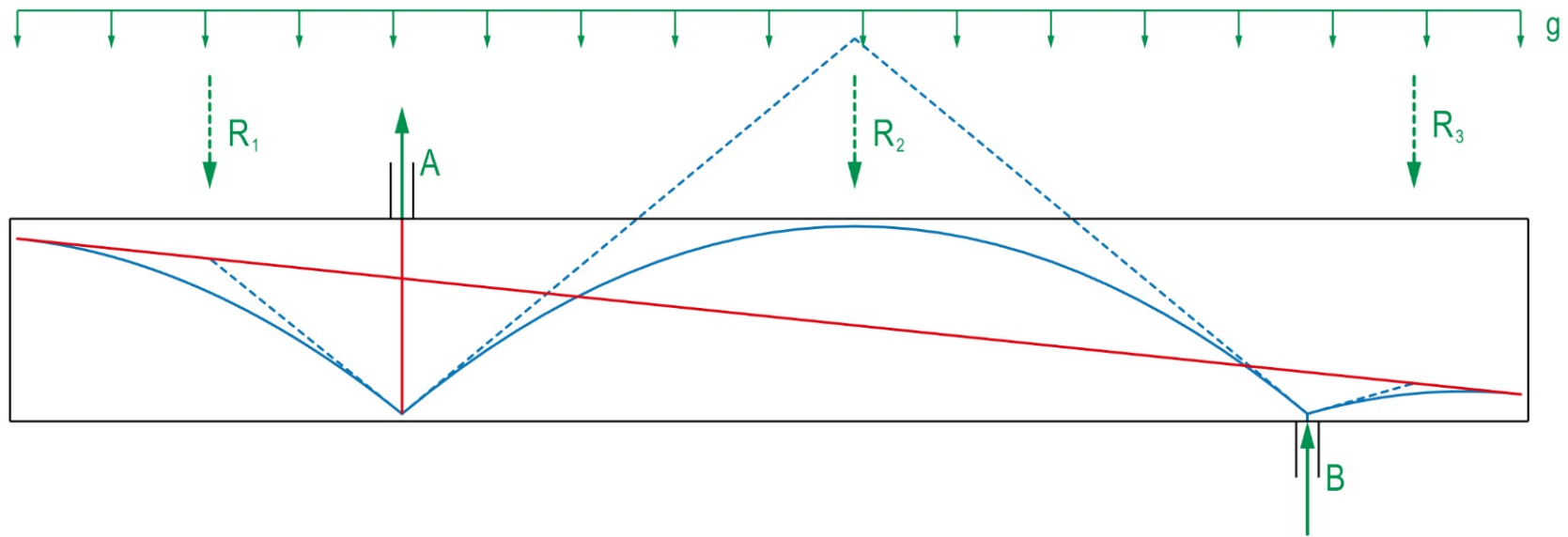
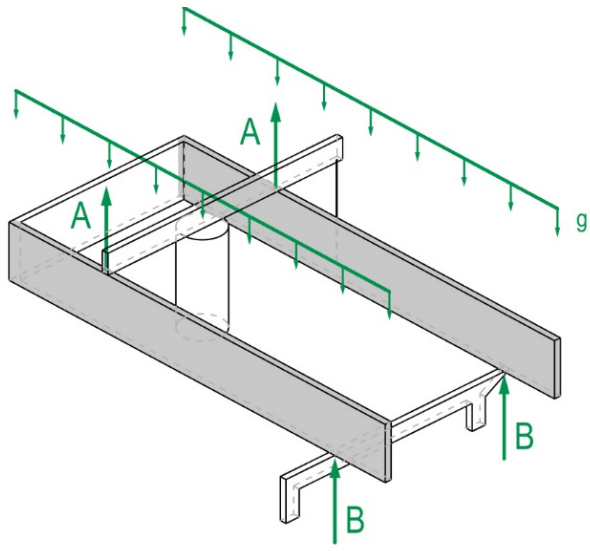

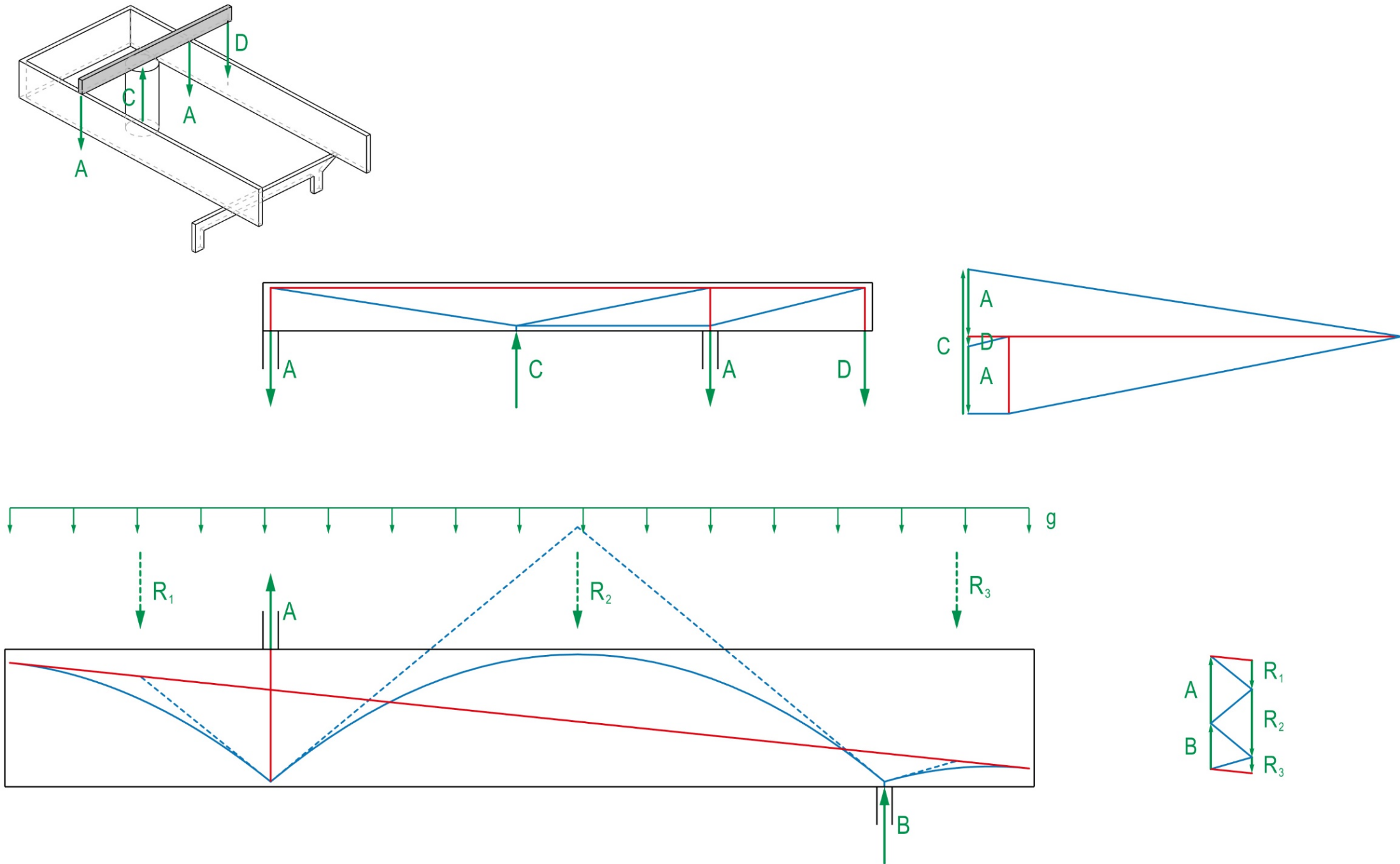

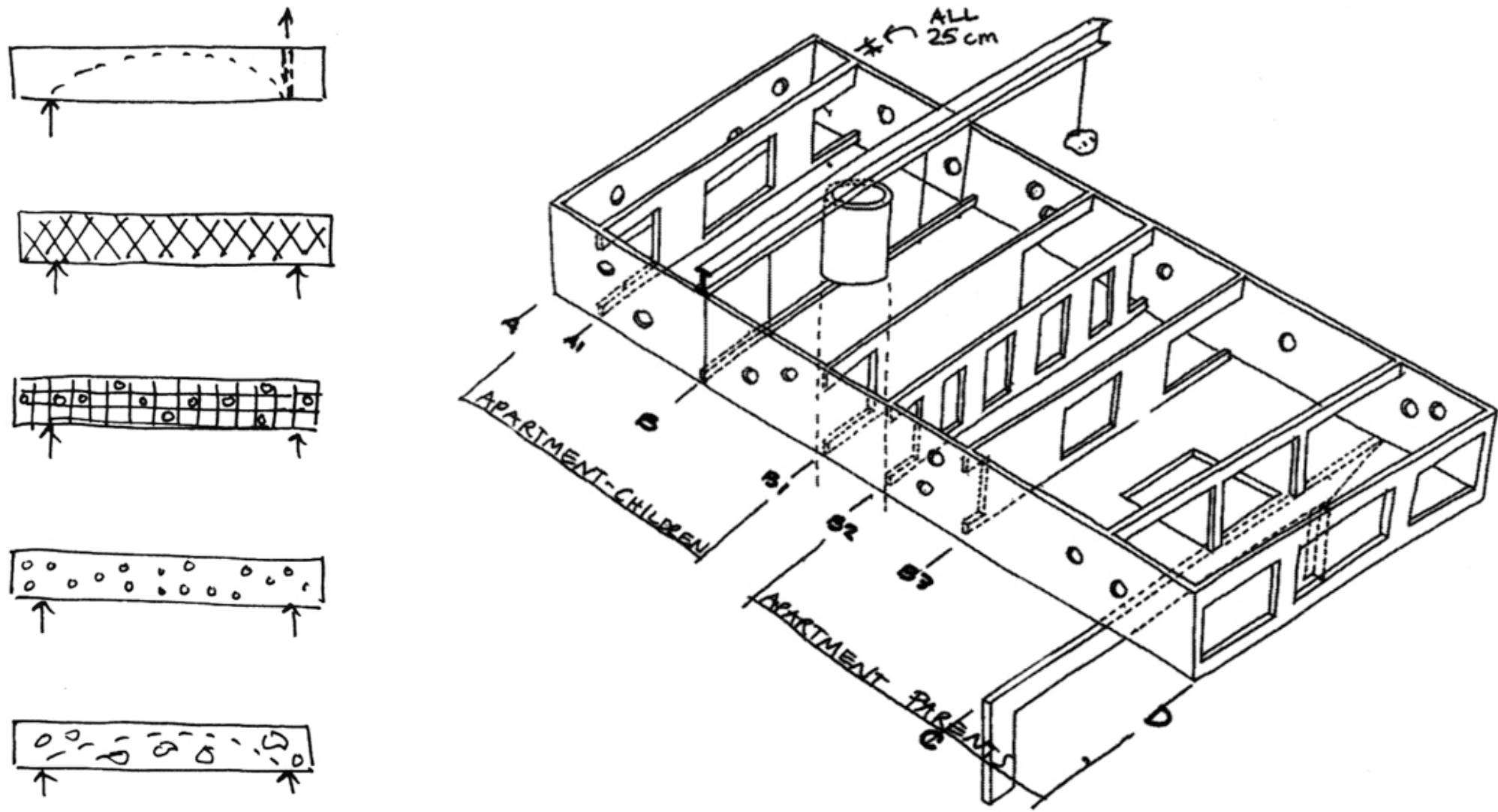

Maison à Floirac, Bordeaux, 1994-1998, Arch.: Rem Koolhaas, Ing: Cecil Balmond.

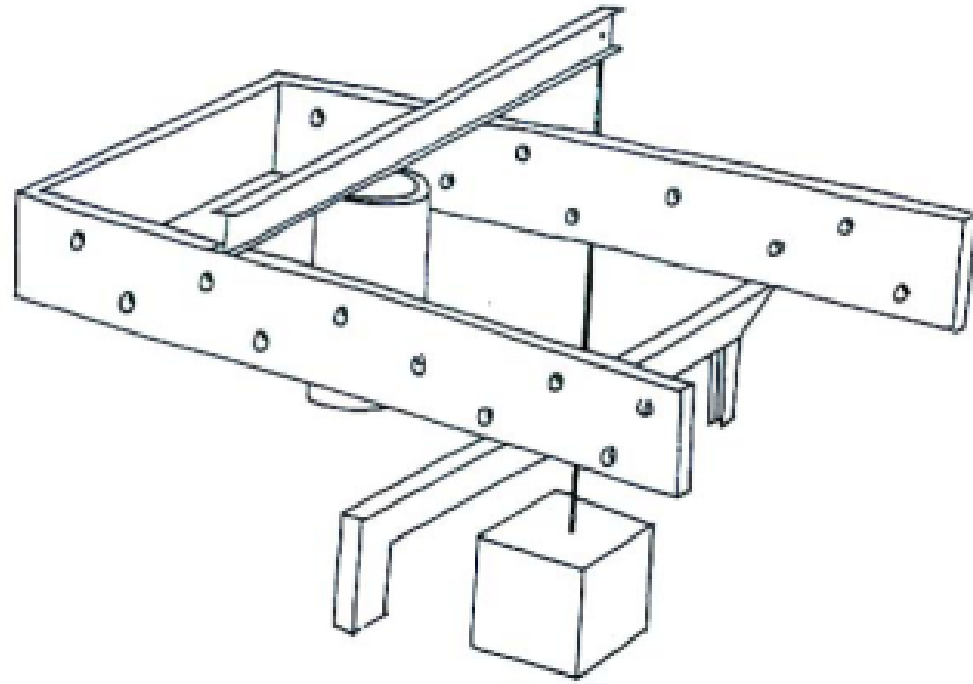



Maison à Floirac, Bordeaux, 1994-1998, Arch.: Rem Koolhaas, Ing: Cecil Balmond.



Maison à Floirac, Bordeaux, 1994-1998, Arch.: Rem Koolhaas, Ing: Cecil Balmond.





Maison à Floirac, Bordeaux, 1994-1998, Arch.: Rem Koolhaas, Ing: Cecil Balmond.



Maison à Floirac, Bordeaux, 1994-1998, Arch.: Rem Koolhaas, Ing: Cecil Balmond.



Maison à Floirac, Bordeaux, 1994-1998, Arch.: Rem Koolhaas, Ing: Cecil Balmond.

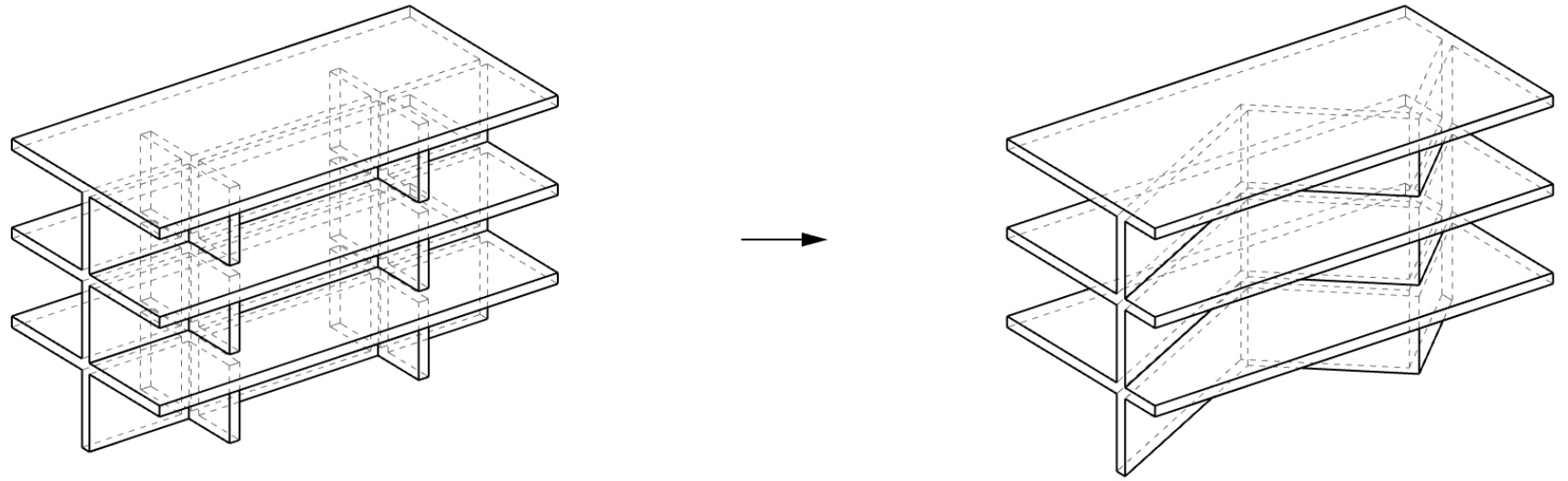





Das Haus mit einer Wand, Zürich, 2007, Arch.: Christian Kerez, Ing.: Joseph Schwartz



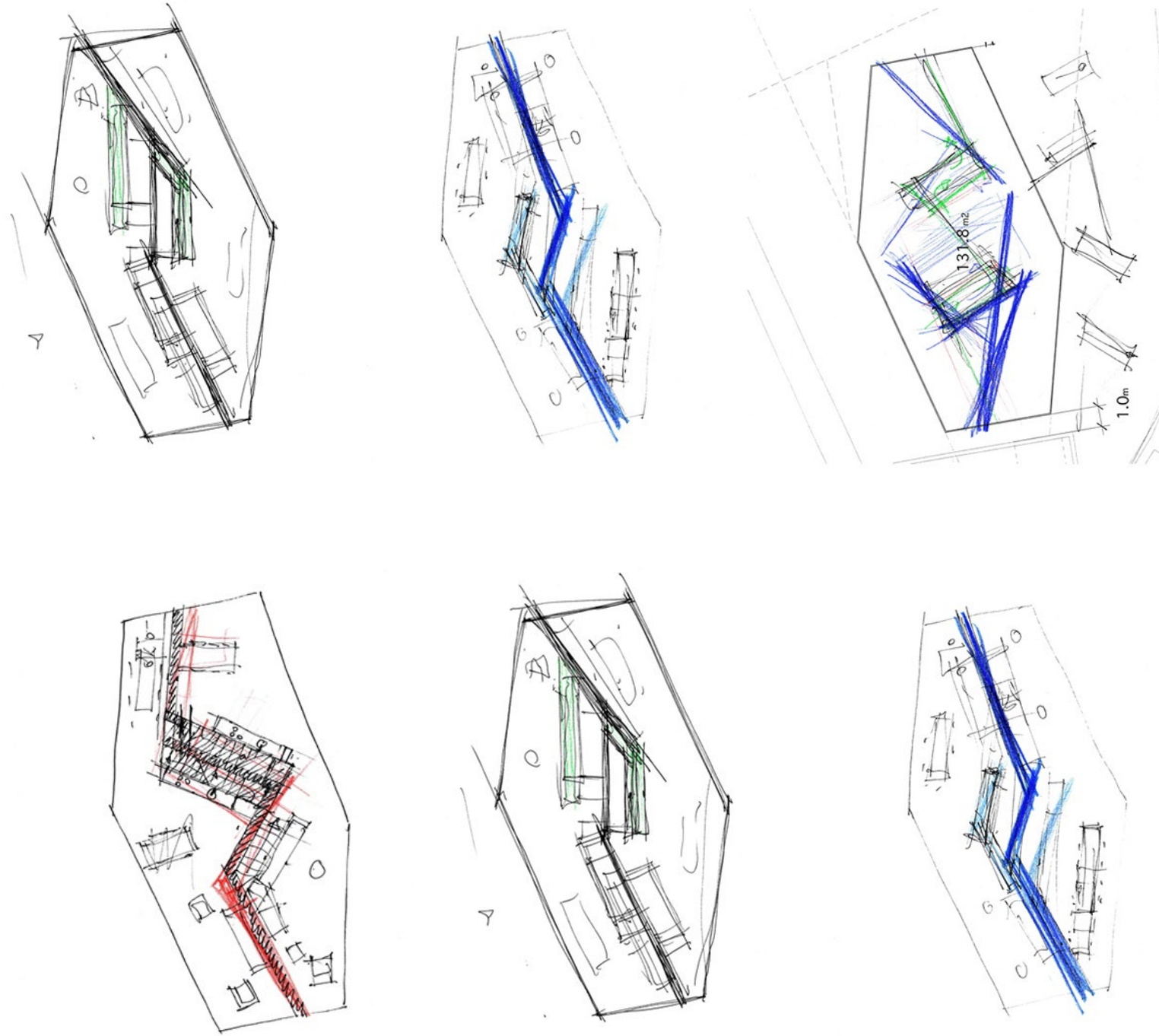

Das Haus mit einer Wand, Zürich, 2007, Arch.: Christian Kerez, Ing.: Joseph Schwartz

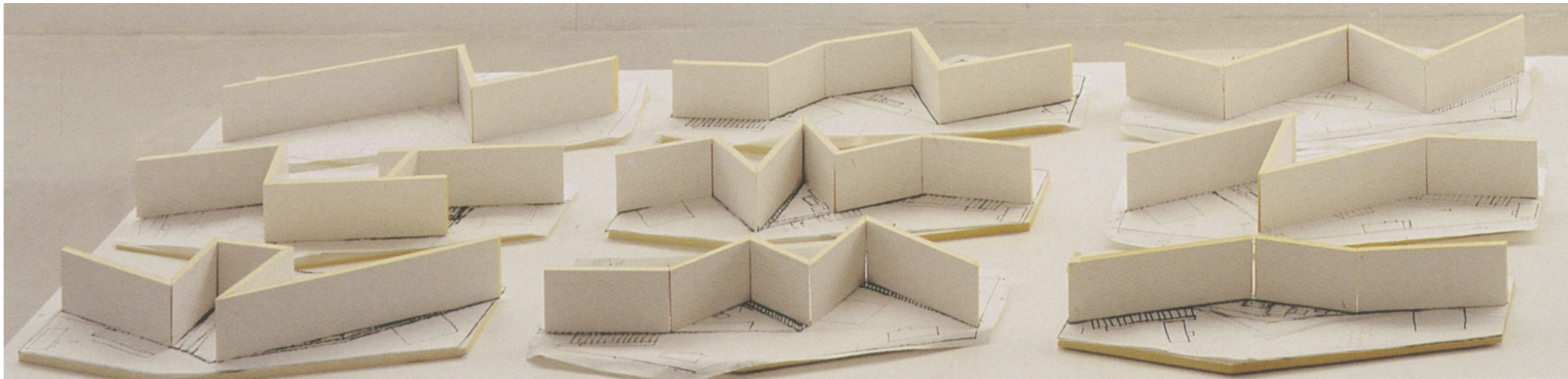

Das Haus mit einer Wand, Zürich, 2007, Arch.: Christian Kerez, Ing.: Joseph Schwartz





Das Haus mit einer Wand, Zürich, 2007, Arch.: Christian Kerez, Ing.: Joseph Schwartz

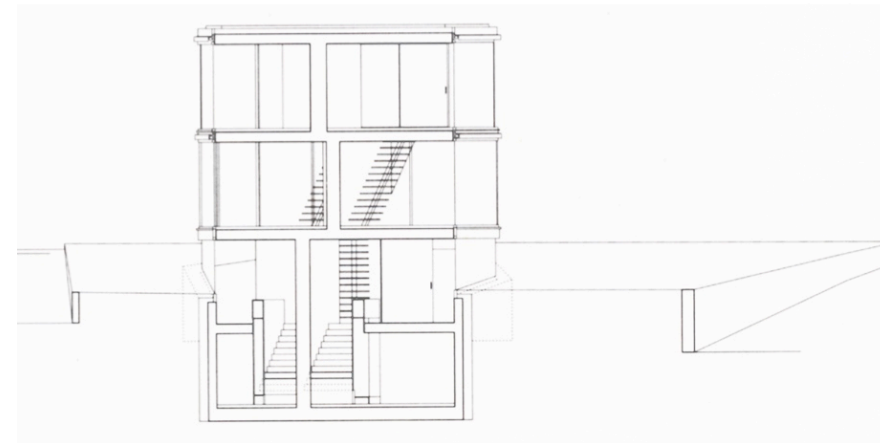
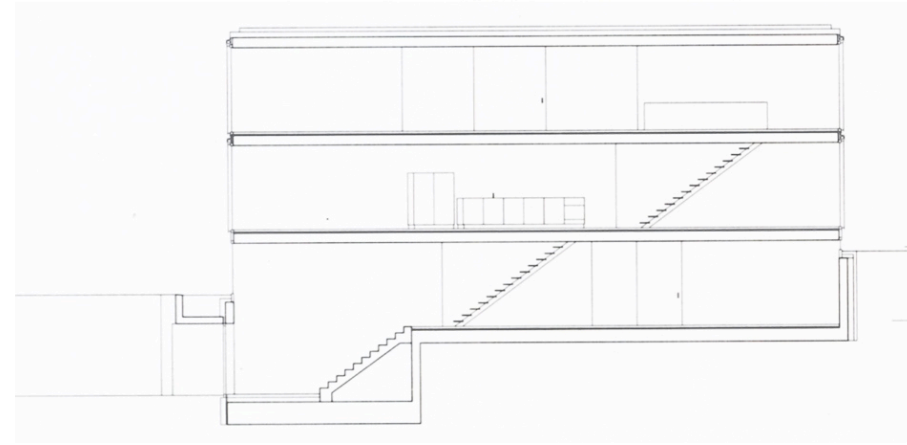
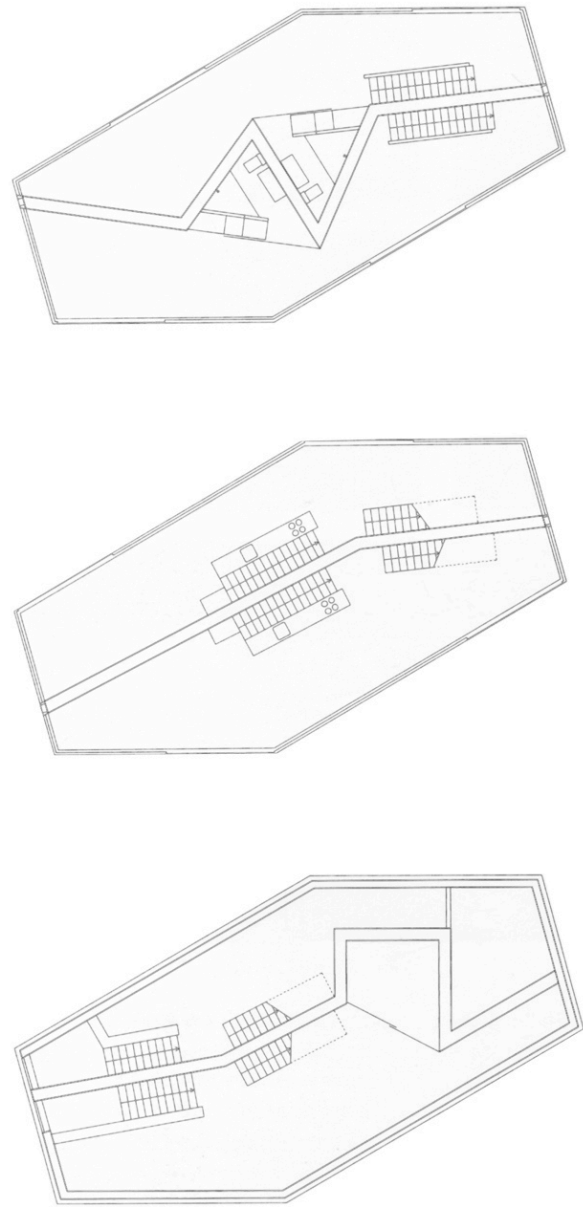

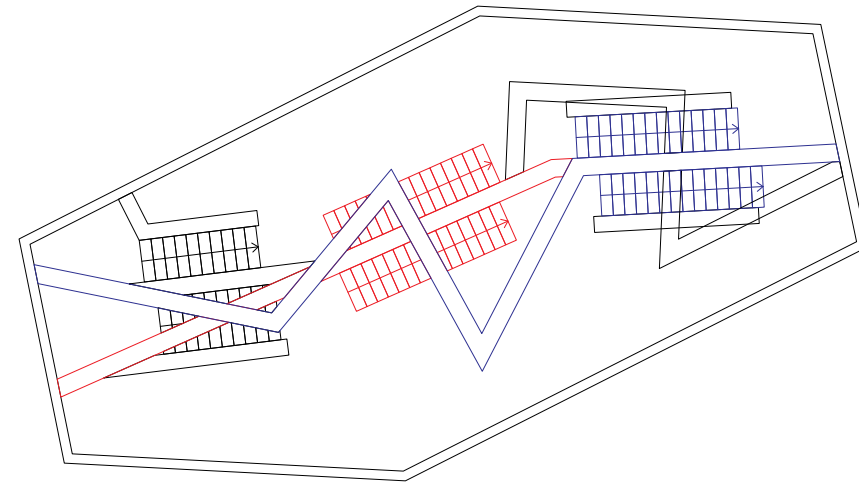
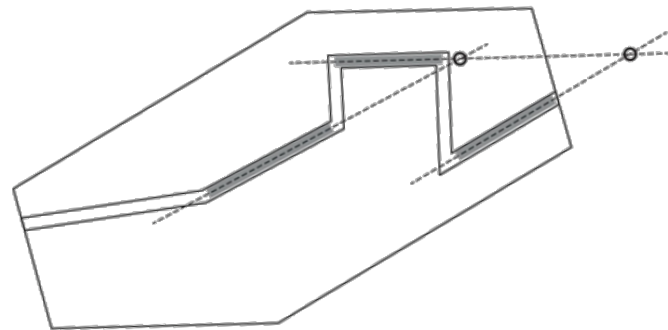
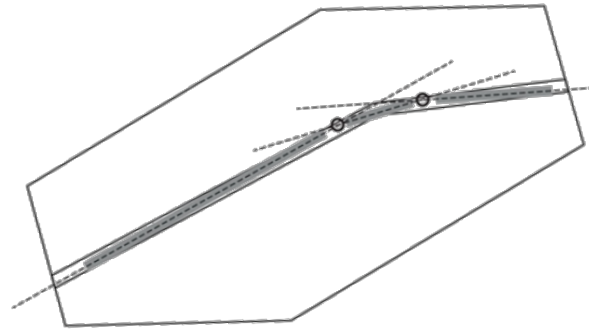
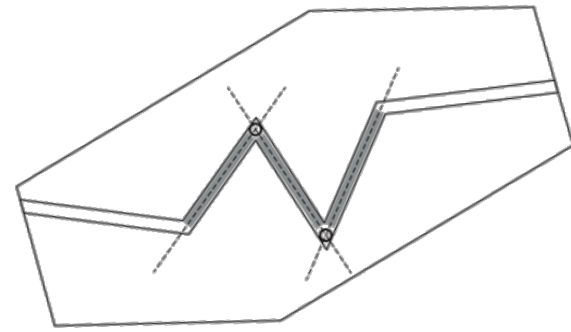



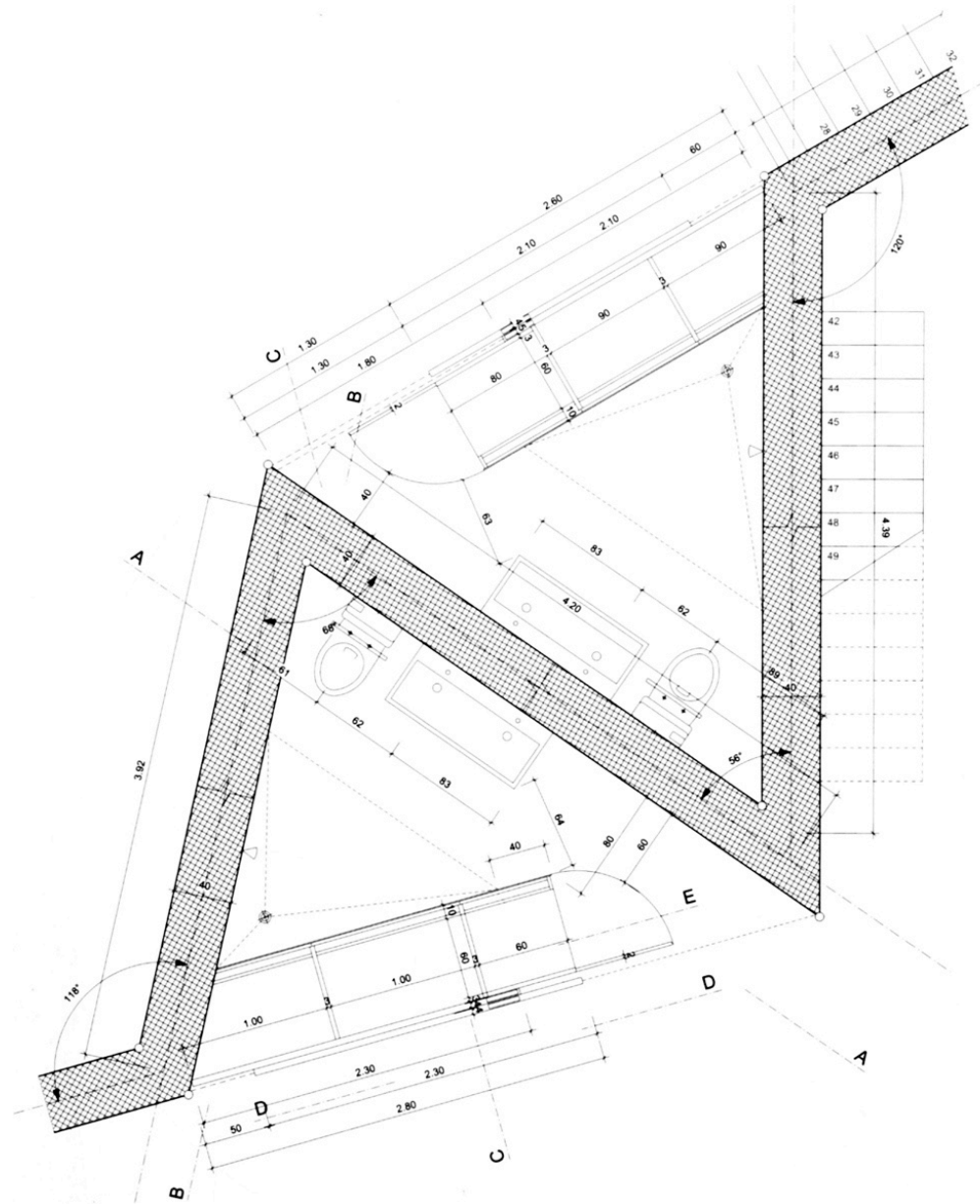

Das Haus mit einer Wand, Zürich, 2007, Arch.: Christian Kerez, Ing.: Joseph Schwartz





Das Haus mit einer Wand, Zürich, 2007, Arch.: Christian Kerez, Ing.: Joseph Schwartz





Das Haus mit einer Wand, Zürich, 2007, Arch.: Christian Kerez, Ing.: Joseph Schwartz

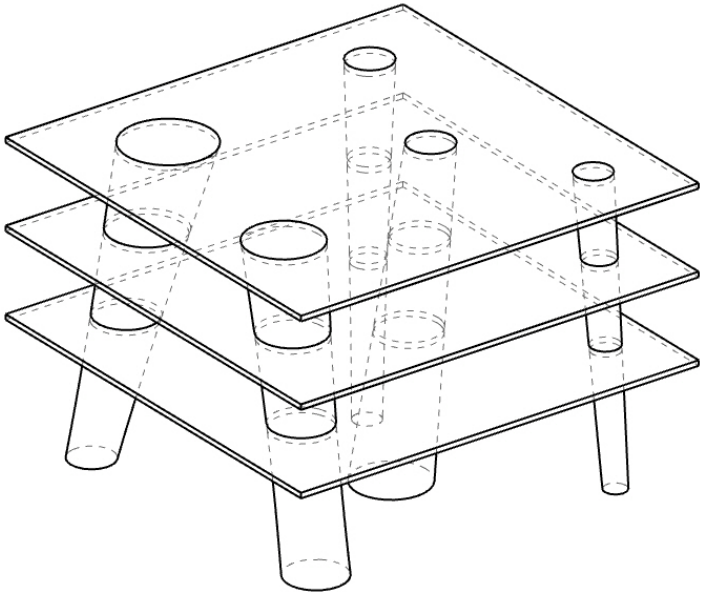
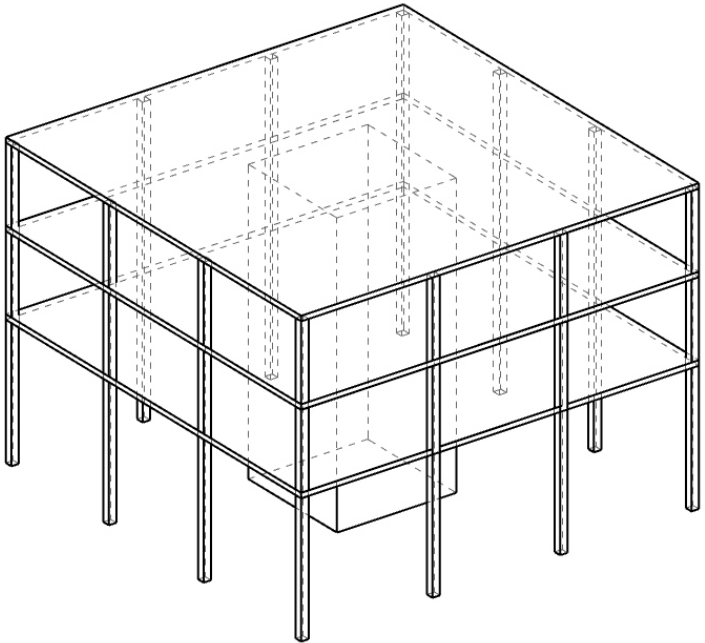





Sendai Mediathek, Sendai, 1995-2001, Arch.: Toyo Ito, Ing.: Mutsuro Sasaki, Sendai



① 徹底的に フリットスラッグ、 海藻のまじり木柱、 フォードのスクリーン  
 の要素だけをピクトに表現する。 どちらかのエレメントを構造的に  
 ととん study し シンプルに ~~表現~~ する = 全力をあげる。 ほか以外はすべて void  
 にした。

⑥ フォードのスクリーンは  
 このスラッグのみ  
 (透明・半透明の  
 フィルムはいい)

⑤ スラッグは極力小さく  
 フリット Floor Height  
 はシンプル

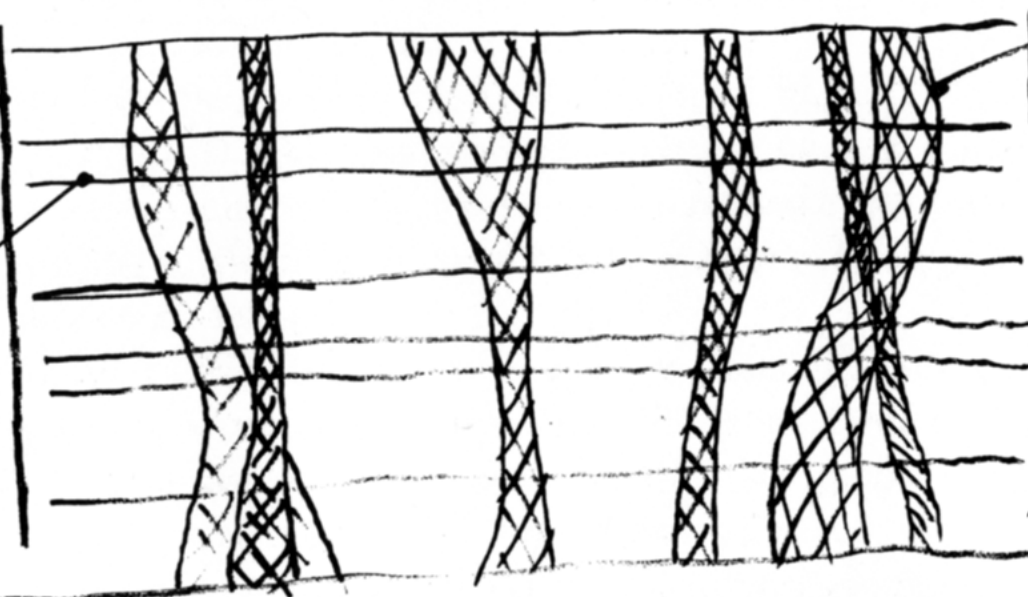

steel pipe ②  
 の軸が曲がる。  
 どちら  
 金太極に  
 欠点があるのか。  
 ?



③ GP. 言語的 EU  
 をビビッと金太

表 ← グラデーション → 裏  
 木柱のなかか void から 密実なモノへ

④ 変化する

23. Jan '95  
 Toyo Ito

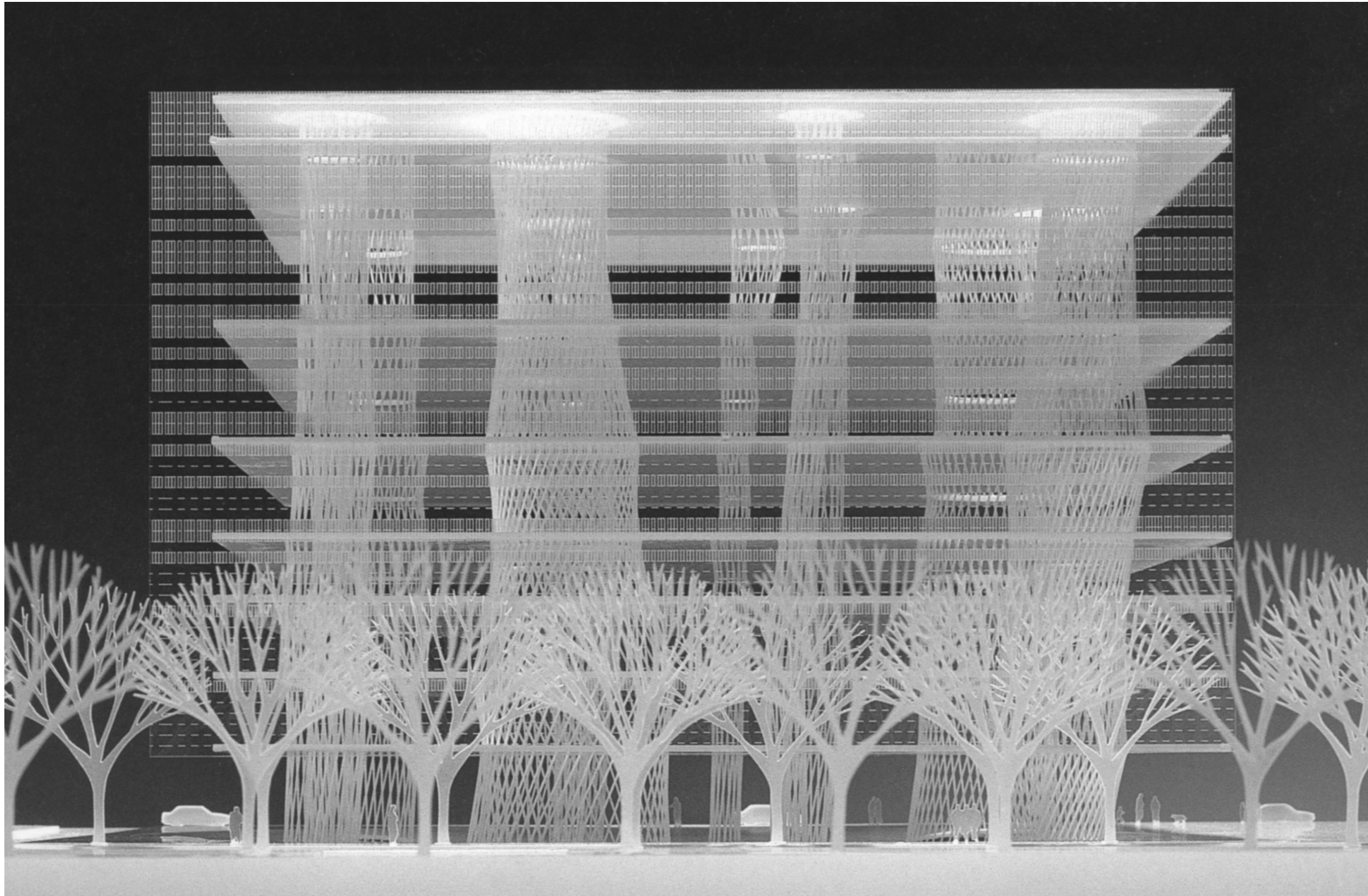

Sendai Mediathek, Sendai, 1995-2001, Arch.: Toyo Ito, Ing.: Mutsuro Sasaki, Sendai

“...the image was poetic, but far from any known reality...”

Mutsuro Sasaki's first reaction to Ito's sketch

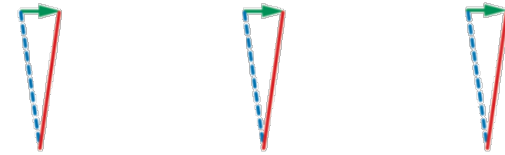
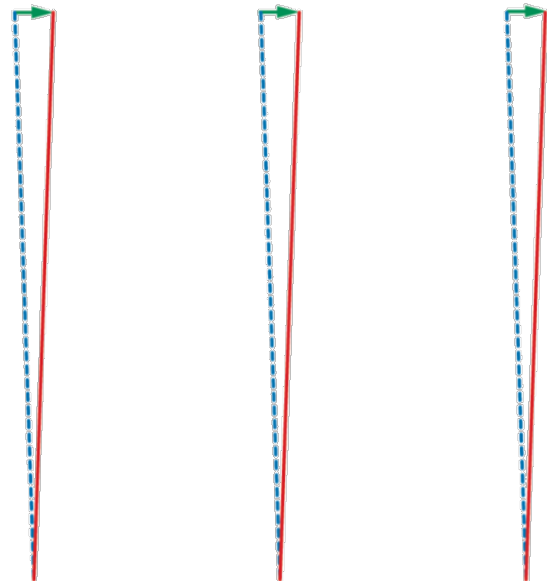
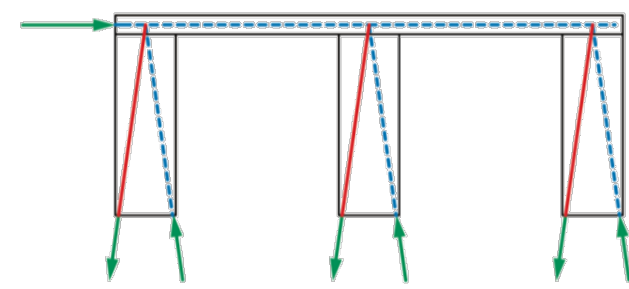
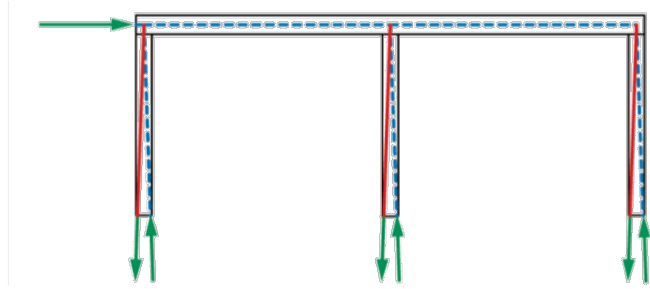

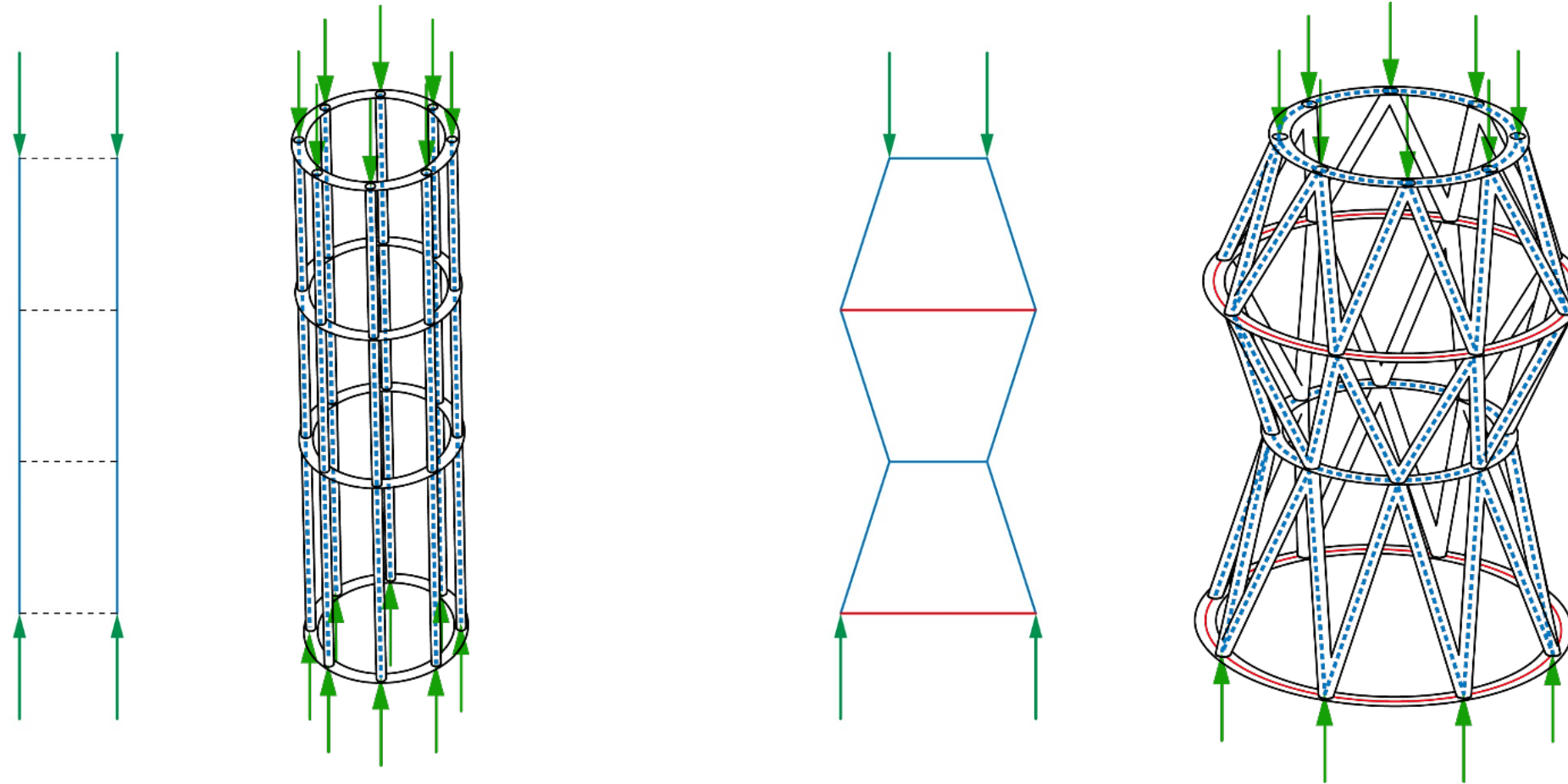



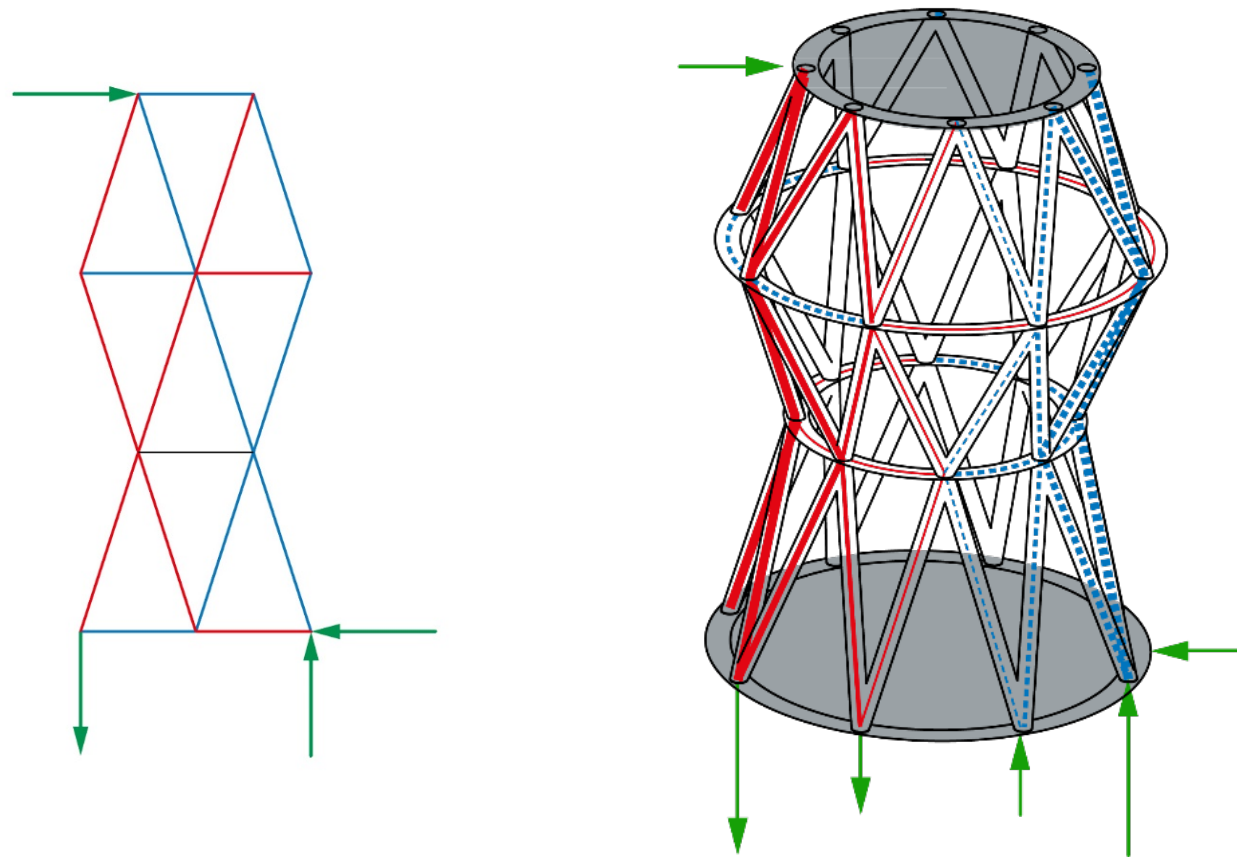

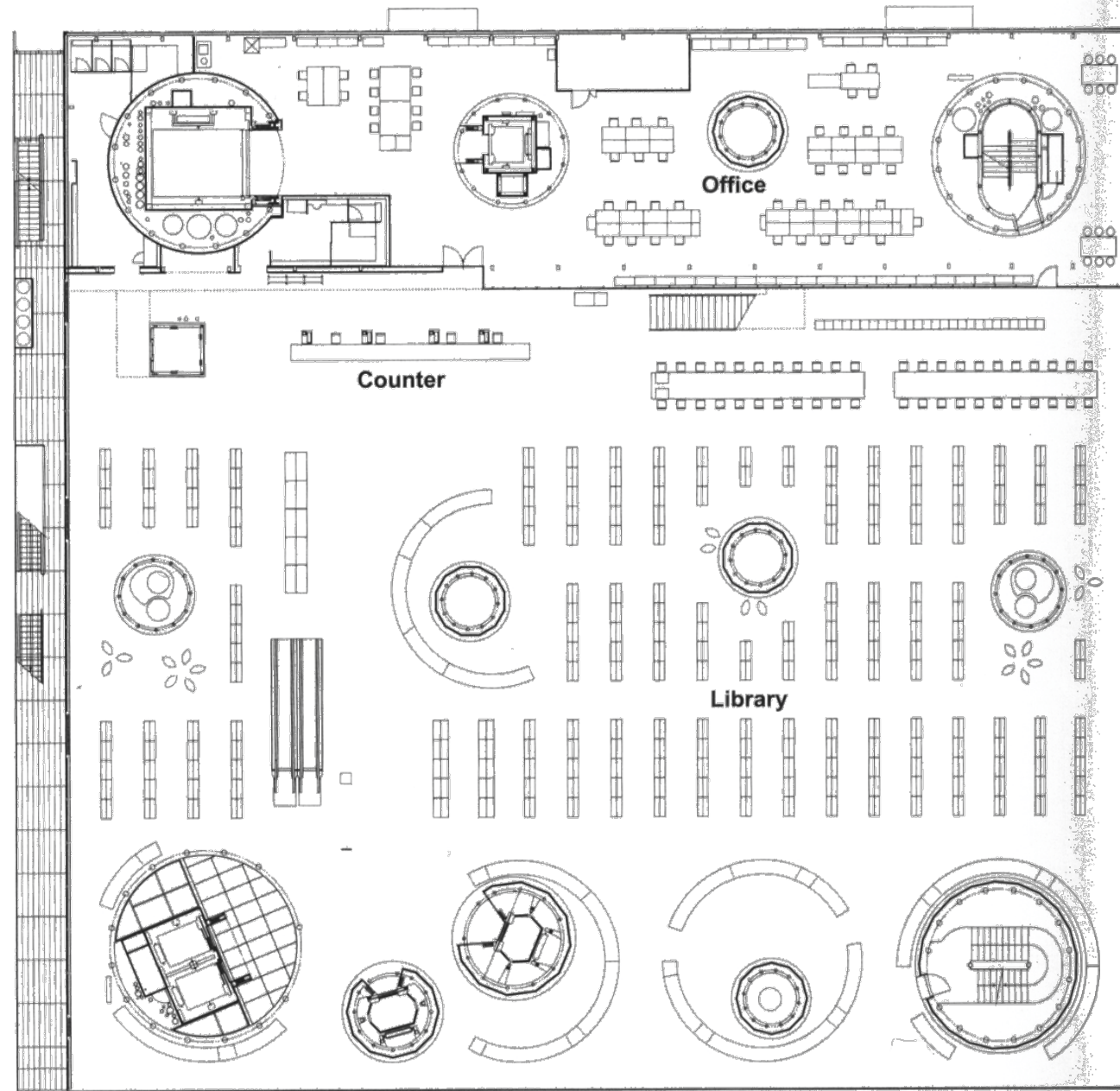

Sendai Mediathek, Sendai, 1995-2001, Arch.: Toyo Ito, Ing.: Mutsuro Sasaki, Sendai



Sendai Mediathek, Sendai, 1995-2001, Arch.: Toyo Ito, Ing.: Mutsuro Sasaki, Sendai





Sendai Mediathek, Sendai, 1995-2001, Arch.: Toyo Ito, Ing.: Mutsuro Sasaki, Sendai

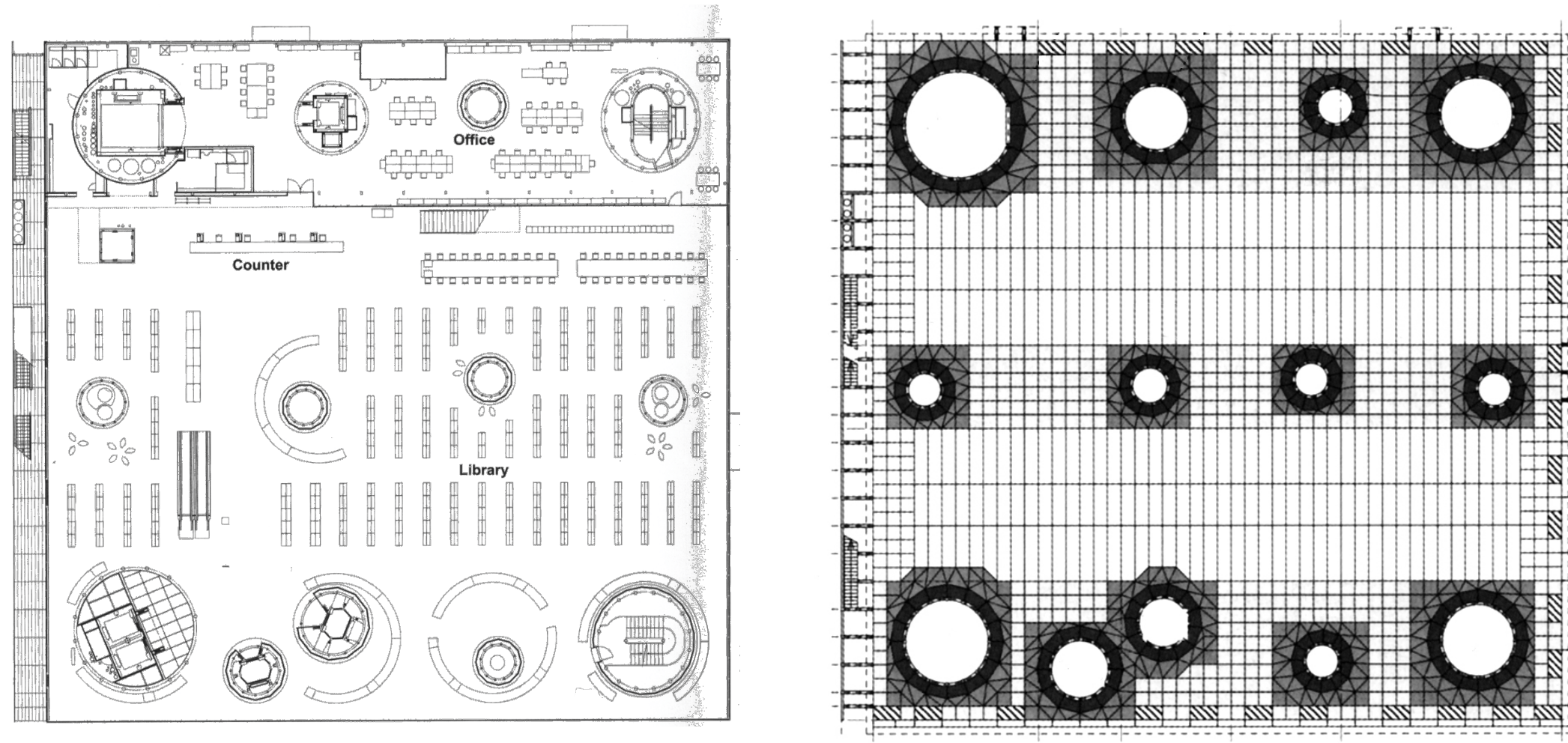





Sendai Mediathek, Sendai, 1995-2001, Arch.: Toyo Ito, Ing.: Mutsuro Sasaki, Sendai



Sendai Mediathek, Sendai, 1995-2001, Arch.: Toyo Ito, Ing.: Mutsuro Sasaki, Sendai



Sendai Mediathek, Sendai, 1995-2001, Arch.: Toyo Ito, Ing.: Mutsuro Sasaki, Sendai

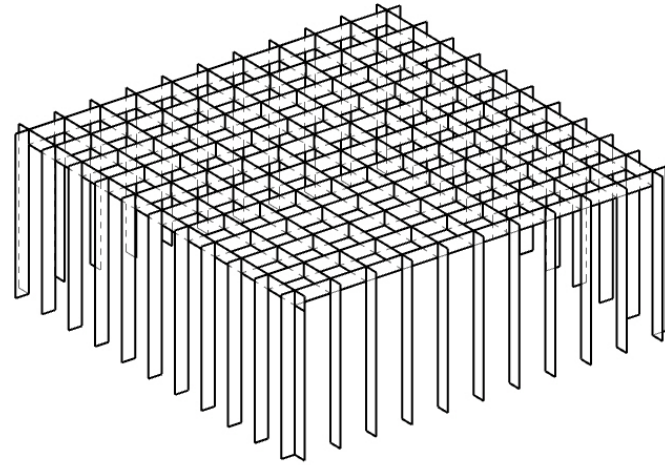
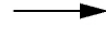
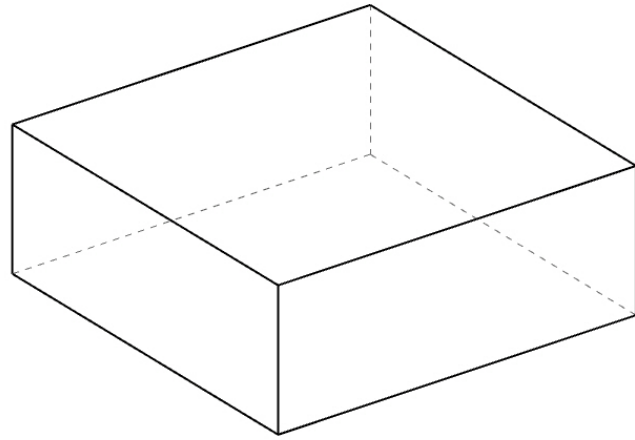





Hilti Pavillon, Schaan, 2016, Arch.: Giuliani Hönger, Ing.: Dr. Schwartz Consulting

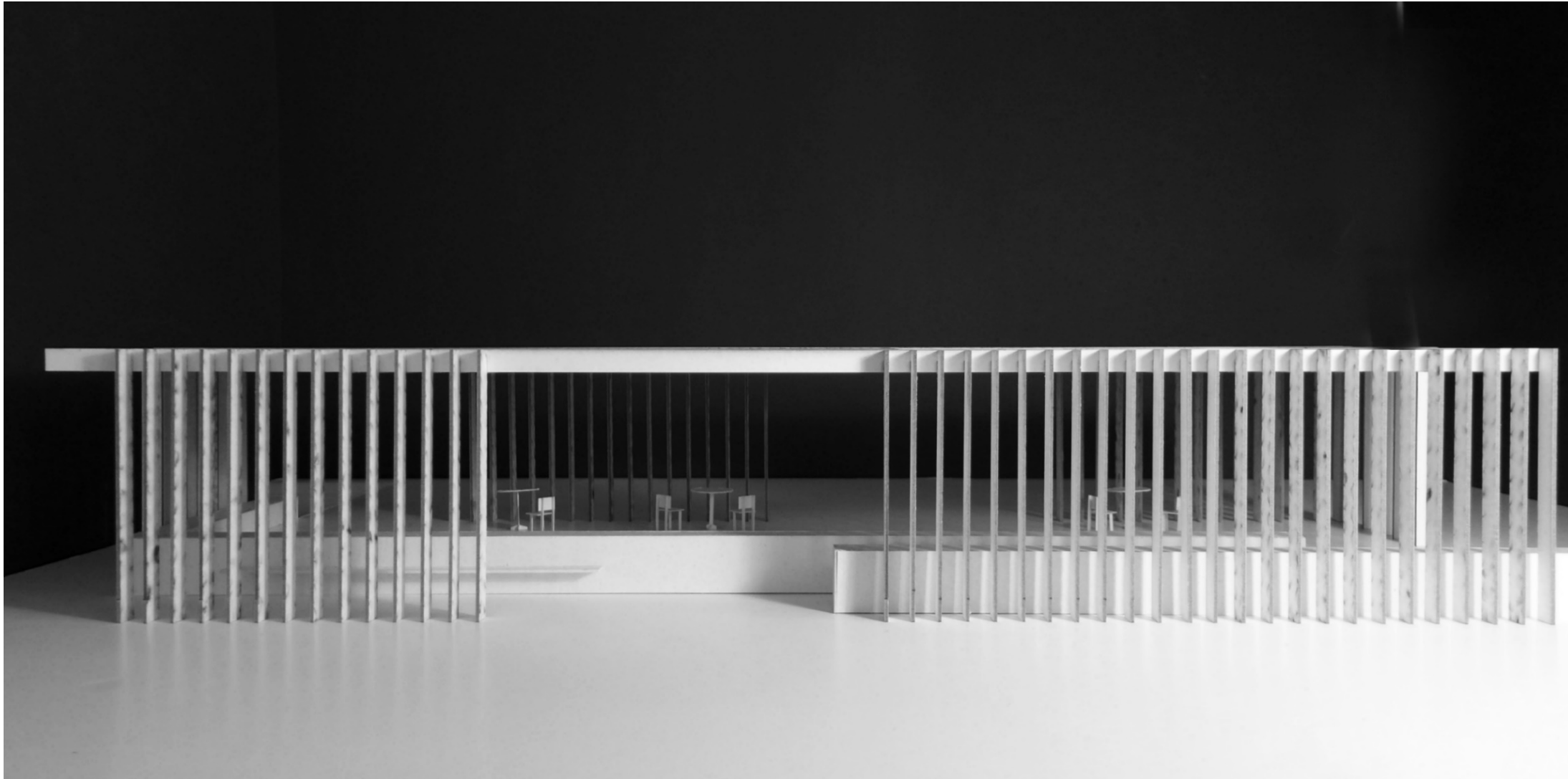

Hilti Pavillon, Schaan, 2016, Arch.: Giuliani Hönger, Ing.: Dr. Schwartz Consulting

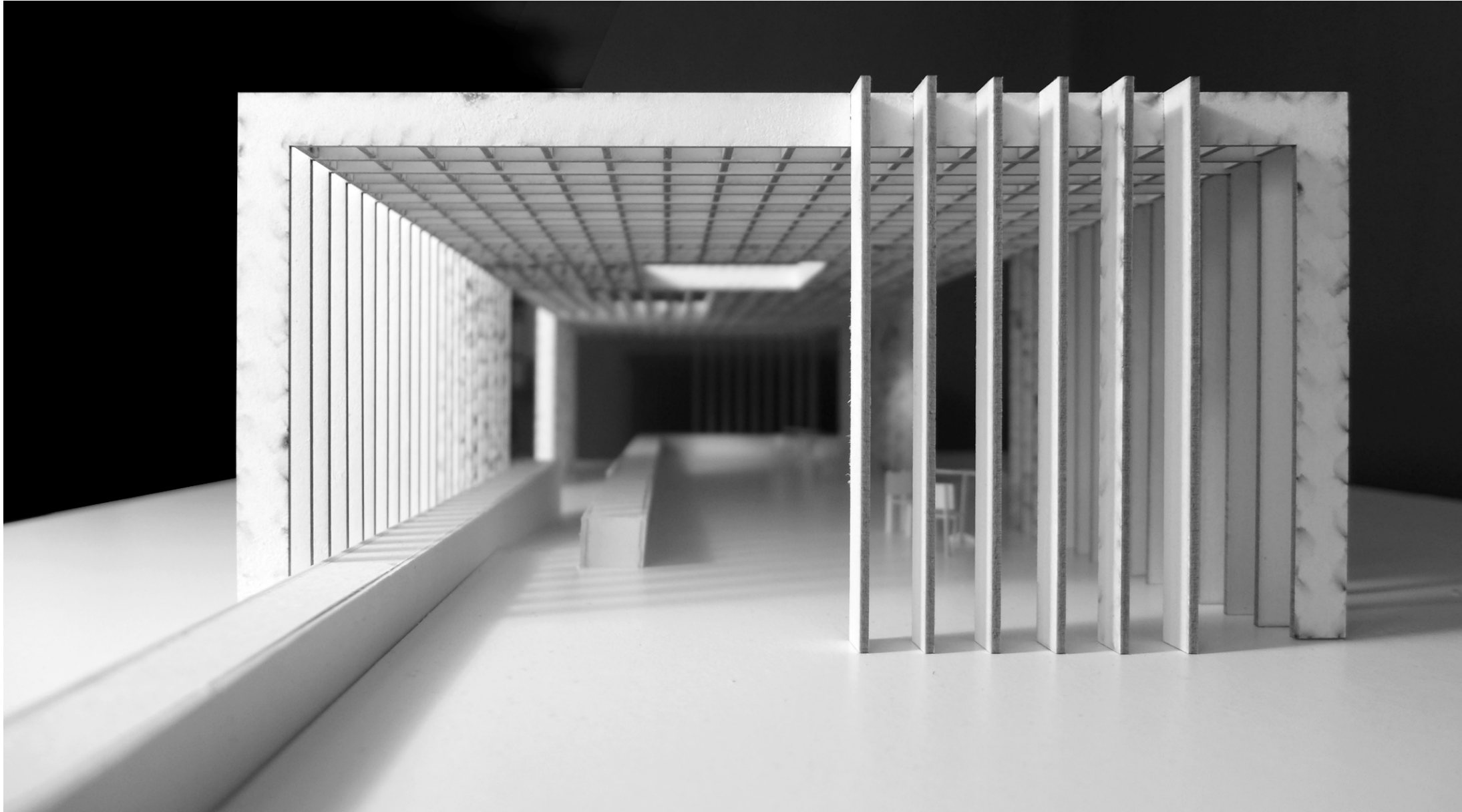

Hilti Pavillon, Schaan, 2016, Arch.: Giuliani Hönger, Ing.: Dr. Schwartz Consulting





Hilti Pavillon, Schaan, 2016, Arch.: Giuliani Hönger, Ing.: Dr. Schwartz Consulting



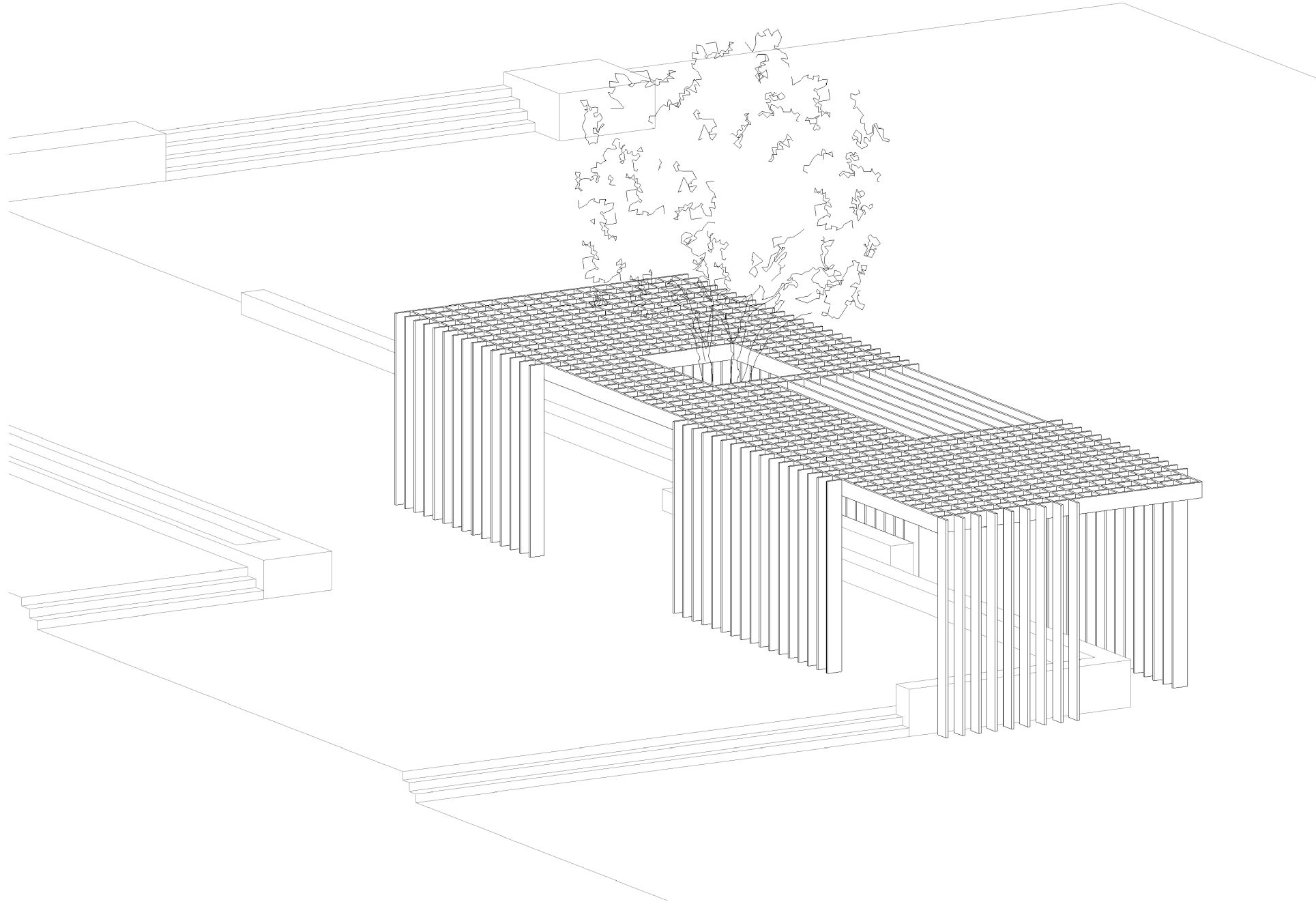

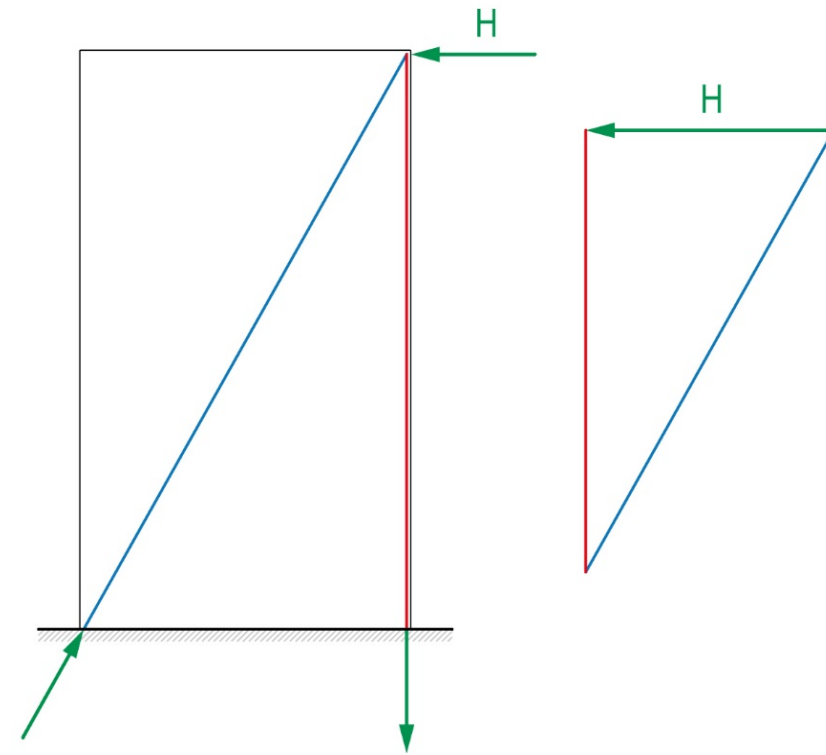
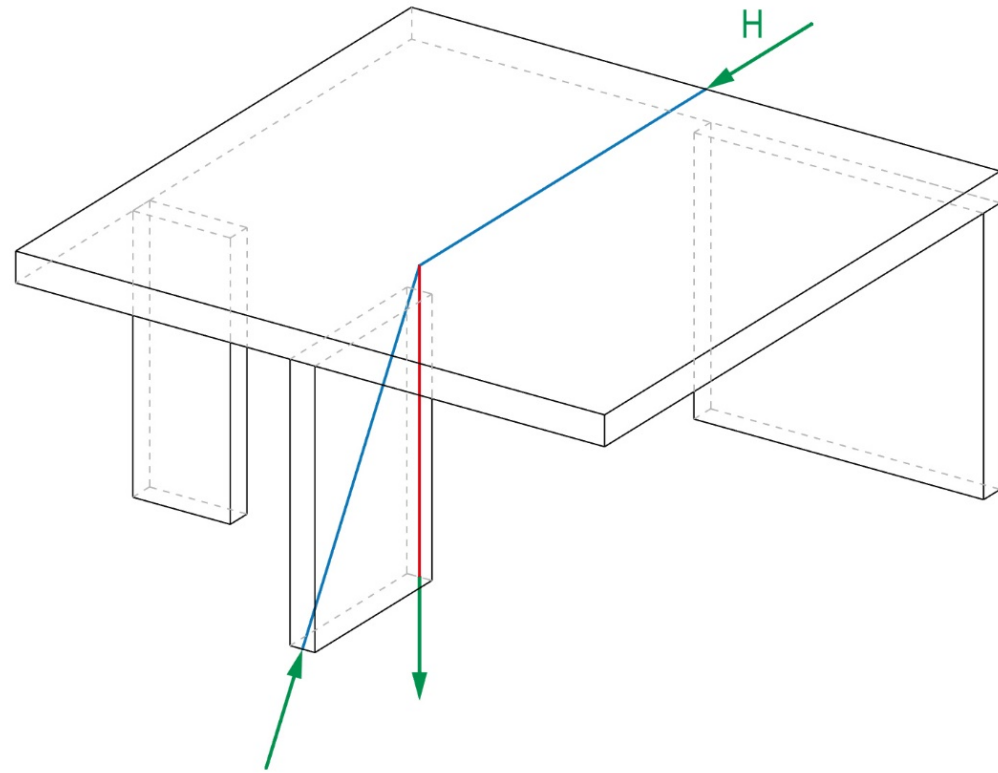

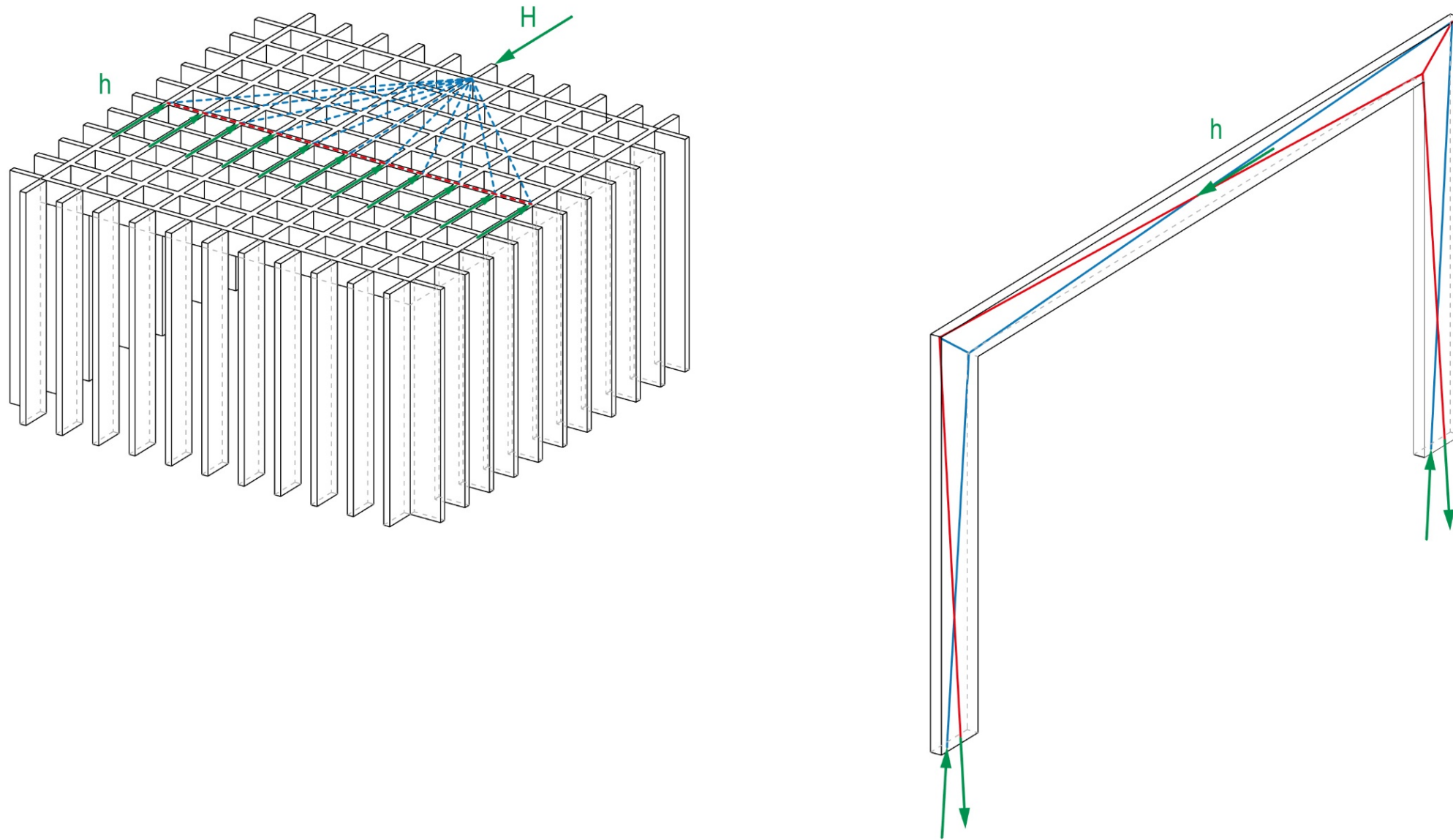

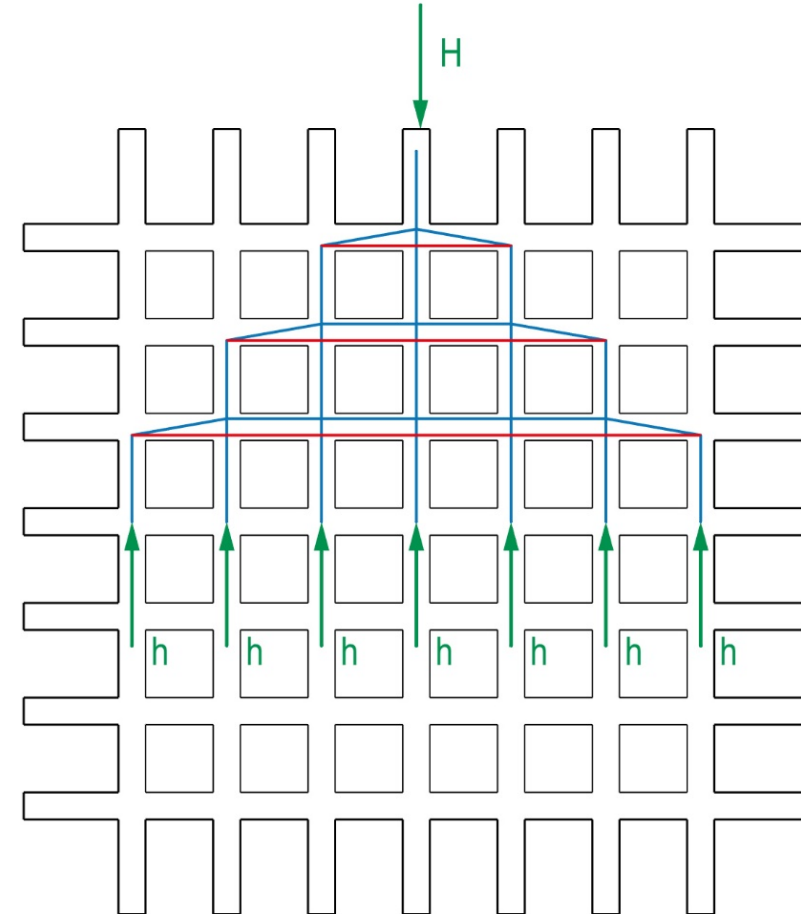
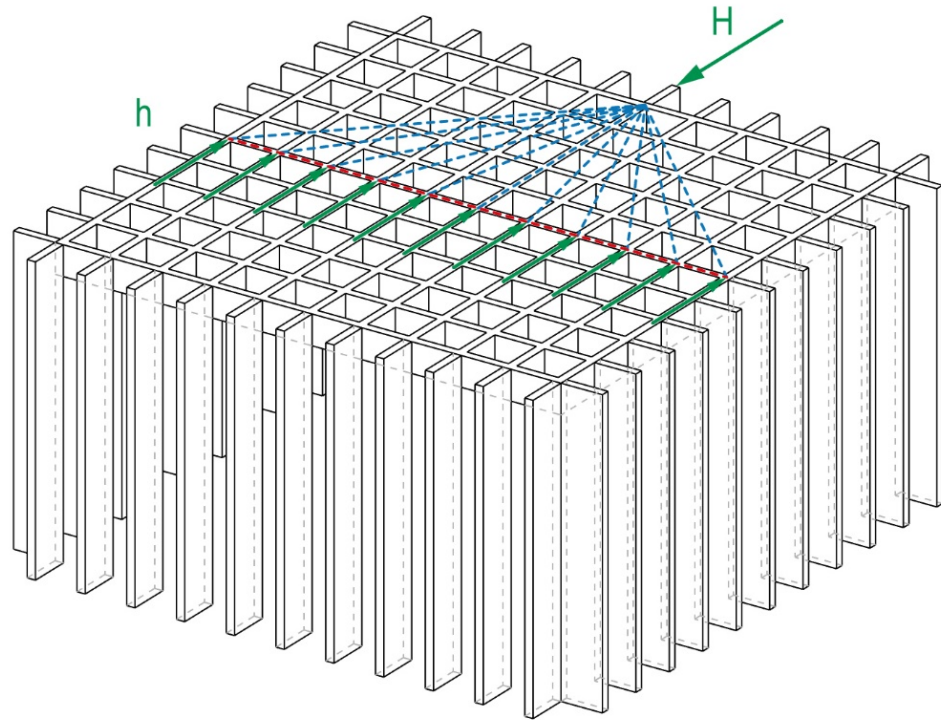





Hilti Pavillon, Schaan, 2016, Arch.: Giuliani Hönger, Ing.: Dr. Schwartz Consulting





Hilti Pavillon, Schaan, 2016, Arch.: Giuliani Hönger, Ing.: Dr. Schwartz Consulting



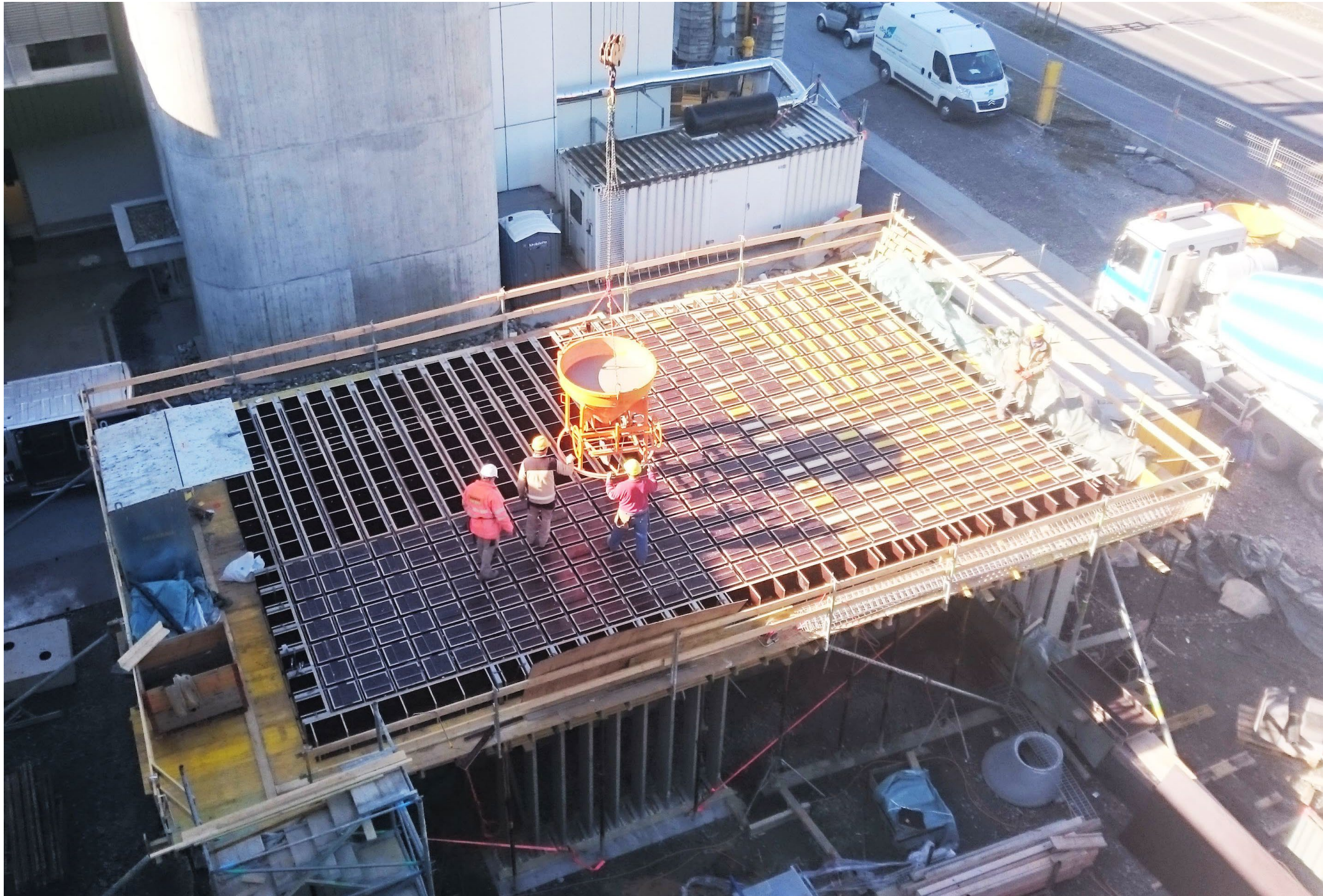

Hilti Pavillon, Schaan, 2016, Arch.: Giuliani Hönger, Ing.: Dr. Schwartz Consulting





Hilti Pavillon, Schaan, 2016, Arch.: Giuliani Hönger, Ing.: Dr. Schwartz Consulting



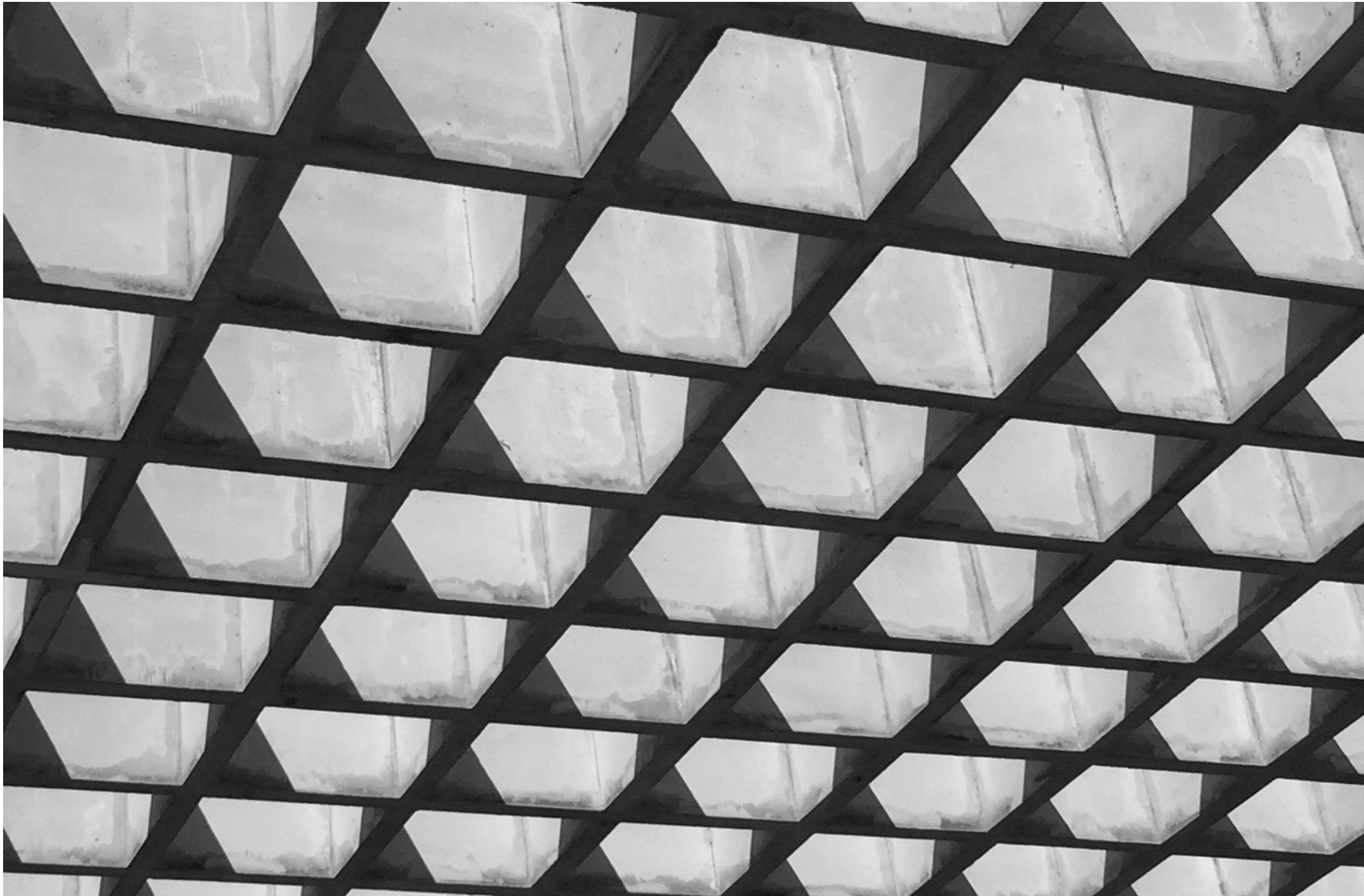

Hilti Pavillon, Schaan, 2016, Arch.: Giuliani Hönger, Ing.: Dr. Schwartz Consulting